



ARO[®]

LEITFADEN ZUR CHEMISCHEN VERTRÄGLICHKEIT

REFERENZLEITFADEN FÜR PUMPEN





- ▀ ARO® stellt Ihnen diesen Auswahl-Leitfaden als einfachen und informativen Referenzpunkt für die Pumpenauswahl zur Verfügung.

Diese Informationen wurden aus Informationen von Materialanbietern und Herstellern zusammengetragen.

Die Kompatibilitätslisten sind nur als Orientierungshilfe gedacht. Wir übernehmen keine Haftung für ihre Richtigkeit bei der Verwendung. Der Benutzer sollte unter den eigenen Betriebsbedingungen Tests vornehmen, um die Eignung aller Verbindungen und Materialien für eine spezifische Anwendung festzustellen.

➤ **THERMOPLASTISCHE ELASTOMERE (TPEs) vgl. mit DUROPLASTISCHEN GUMMIMEMBRANEN**

ARO tendiert zum Ersetzen von herkömmlichen duroplastischen Gummimembranen durch thermoplastische Elastomere (TPE). TPEs sind unter anderem: Santoprene®, Nitrile (TPE) und Hytrel®.

TPEs werden mithilfe eines Kunststoff-Spritzguss-Verfahrens gefertigt, bei dem Harz, oder das Membranmaterial, geschmolzen und dann in eine Form gespritzt wird. Dieser Prozess hat folgende Vorteile:

Merkmale	Vorteile
Membran wird in eine optimale Form gegossen	Hervorragende Flex-Lebensdauer
Teil aus einem Stück	Keine Ablösung von Schichten
Leistungsfähige Harze	Chemisch, Abrieb und Flex-Lebensdauer
Spritzguss/präzise Prozesssteuerung	Niedrige Kosten/konstante Leistung

Spritzgussverfahren

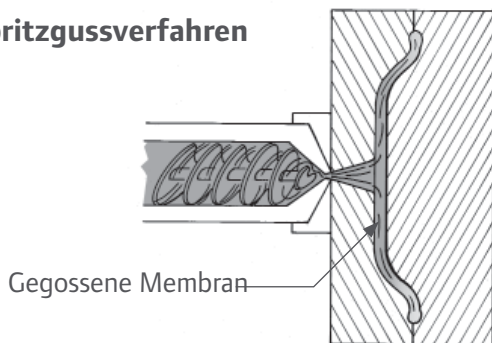

Duroplastgussverfahren (Laminierung)

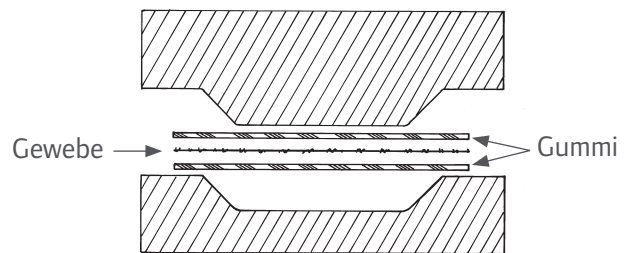

➤ **LABORTESTS HABEN GEZEIGT:**

Santoprene® erzielte in milden, abrasiven Medien eine bessere Leistung als alle Gummimembranen außer Buna. Die Geolast-Membran erreichte die gleiche Lebensdauer wie Buna-Membranen und war den anderen Gummiverbindungen überlegen.

PTFE mit der Santoprene®-Stütze erzielte während der Testreihe die beste Flex-Lebensdauer aller Membranen.

➤ **HERKÖMMLICHES DUROPLAST UMFASST U. A.: BUNA-N (TS), EPR, NEOPRENE®, VITON®**

Duroplast-Membranen werden durch Sandwichbauweise (Laminierung) hergestellt, bei der eine Schicht Gewebe zwischen zwei Schichten aus unvulkanisiertem Gummi angebracht wird. Der Prozess findet in einer Form statt, in der das Material unter Hitze und hohem Druck aufeinandergespreßt wird. Dadurch verbinden sich die Materialien und der Gummi wird vulkanisiert.

Dieser Prozess hat jedoch einige Nachteile:	Ergebnisse
Durch die Umschließung des Gewebes wird die Designflexibilität zum Erzielen einer optimalen Membranform eingeschränkt	Geringere Flex-Lebensdauer
Das Gewebe bleibt nicht zwischen zwei Gummischichten zentriert	Schlechter Abrieb/chemischer Angriff
Es kann zu einer unvollständigen Verbindung kommen	Ablösung von Schichten
Zeit-/Arbeitsintensiv	Teuer
Schwankende Qualität	Schwankende Lebensdauer
Dochtwirkung des Gewebes	Ablösen von Schichten/Lecks

➤ THERMOPLASTISCHE VERBINDUNGEN (TPE)

Membranen aus thermoplastischen Elastomeren (TPE) werden über ein Spritzgussverfahren hergestellt. Durch dieses Verfahren kann die Membran in der Form und Konfiguration gegossen werden, die zur höchsten Leistung und Lebensdauer führt. Die TPE-Harze, die zur Herstellung der Membranen verwendet werden, verfügen über hervorragende maßliche Merkmale und Dehnverhältnisse, wodurch eine Verstärkung mit Gewebe nicht mehr erforderlich ist. In den Membranpumpen von ARO werden die folgenden TPEs eingesetzt.

➤ DUROPLAST (TS)

Diese Materialien bestehen aus Naturkautschuk und künstlichen Zusätzen, um die Beständigkeit gegen verschiedene Flüssigkeiten zu erhöhen. Membranen werden über ein Formpressverfahren hergestellt. In der Membran wird ein Nylon-Gewebe angebracht, um die Verbindung zu stärken.

➤ PTFE

Die chemisch beständigste künstliche Verbindung. Das neue Membrandesign und das Materialverfahren haben die Flex-Lebensdauer erheblich verbessert. Sie ist gleich hoch oder sogar höher als die von Gummiverbindungen. Über eine Stützmembran wird zusätzliche Unterstützung bereitgestellt.

Bewertung A = Ausgezeichnet B = Gut C = Mittel D = Schlecht	Verbindung	Farbcode	Temperatur Grenzwerte**	Flex-Lebensdauer	Abriebfestigkeit Kugeln (Sitze)	Einsatz mit Säure	Einsatz mit Ätzmitteln	Lösungsmittel (Ketone/Acetate)	Kohlenwasserstoffe Aromatisch/Chloriert	Erdöl/Öle
TPE	Santoprene (Stütze)	Braun (Grün)	-40 ° bis 107 °C	A	A	A	A	B	D	D
	Hytel*	Creme	-29 ° bis 82 °C	A	A	C	B	B	C	A
	Urethan*	Klar	-23 ° bis 66 °C	A	A	D	D	D	D	A
	PTFE	Weiß	4 ° bis 107 °C	A	C	A	A	A	A	A
Gummi	Neopren	Grün	-18 ° bis 93 °C	B	B	C	C	D	D	B
	Nitril (TS) (BUNA-N)	Rot	-12 ° bis 82 °C	B	B	B	C	C	C	A
	Viton	Gelb	-40 ° bis 177 °C	C	B	A	A	B	A	A
	EPR/EPDM	Blau	-51 ° bis 138 °C	B	B	B	A	B	D	D

* Nicht bei allen Modellen verfügbar

**Die Maximaltemperaturbeschränkungen basieren nur auf mechanischer Beanspruchung. Einige Chemikalien können die sichere maximale Betriebstemperatur deutlich reduzieren

Halogenhaltige Lösungsmittel Explosionsgefahr

Pumpenmodelle mit befeuchteten Aluminiumteilen dürfen nicht mit 111.-Trichlorethylen, Methylenchlorid oder anderen halogenhaltigen Kohlenwasserstofflösungsmitteln verwendet werden, da diese reagieren und explodieren können. Hersteller fügen zwar normalerweise Hemmmittel hinzu, um eine Reaktion zu vermeiden, doch es gibt keine Garantie, dass dadurch unter jeder Bedingung eine Reaktion vermieden wird. Bei zurückgewonnenen oder gebrauchten Lösungsmitteln sollte besonders vorsichtig vorgegangen werden, da sich die Hemmmittel oft abbauen. Für diese Materialien sollten nur Edelstahl-, Acetal- oder PVDF-Pumpen verwendet werden. Weitere Beispiele von halogenhaltigen Kohlenwasserstofflösungsmitteln (H.H.C.) sind: Trichlorethan, Methylchlorid, Kohlenstofftetrachlorid, Chloroform Dichlorethylen.

LEITFADEN ZUR MATERIALKOMPATIBILITÄT DER NASSPARTIE

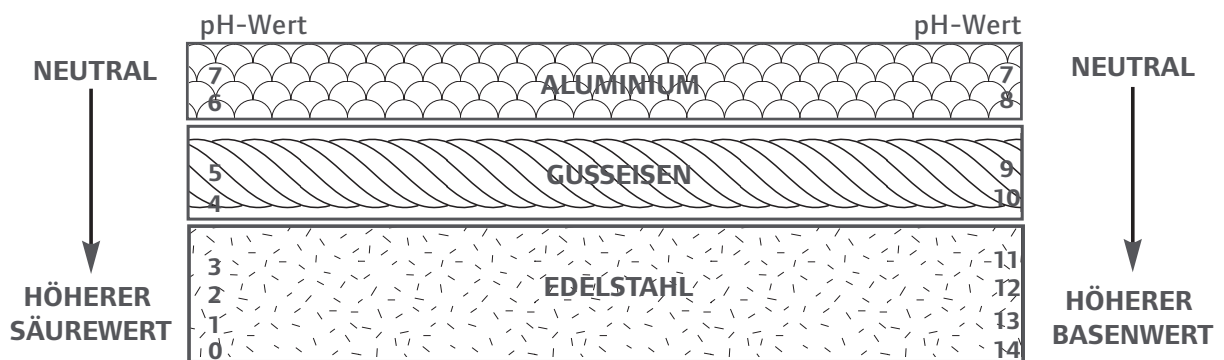

NICHTMETALLISCH

Polypropylen – Ein kostengünstiges Universalmaterial mit weitgehender chemischer Beständigkeit für den Einsatz bei einer Vielzahl chemischer Anwendungen.

Kynar (PVDF) – Ein Hochleistungs-Fluorpolymerharz mit hervorragender chemischer Beständigkeit. Für den Einsatz mit aggressiven Chemikalien bei erhöhten Temperaturen. Weist auch hervorragende mechanische Eigenschaften auf.

Erdbares Acetal – Ein hervorragendes Material für den Transfer von Lösungsmitteln. Das Material beinhaltet Metallfasern, um das Material leitfähig zu machen und so den Aufbau und die potenzielle Abgabe statischer Ladung zu verhindern.

Bewertung

A = Ausgezeichnet
 B = Gut
 C = Mittel
 D = Schlecht

Nichtmetallisch Materialien der Nasspartie	Temperatur- grenzwerte**	Einsatz mit Säure	Einsatz mit Ätzmitteln	Lösungsmittel (Ketone/Acetate)	Kohlenwasserstoffe Aromatisch/Chloriert
Polypropylen	0 ° bis 79 °C	A	A	-	-
PVDF	-12 ° bis 93 °C	A	A	*	*
Erdbares Acetal	-29 ° bis 82 °C	D	D	A	A

* Leitfaden zur Kompatibilität auf spezifische Lösungsmittel oder Kohlenwasserstoffe prüfen

** Die Maximaltemperatur basiert nur auf mechanischer Beanspruchung. Einige Chemikalien können die sichere maximale Betriebstemperatur deutlich reduzieren

LEITFADEN

A = Ausgezeichnet, B = Gut, C = Mittel bis Schlecht, D = Nicht empfohlen

X oder Klammern um einen Bewertungsbuchstaben bedeuten, dass keine Daten verfügbar sind.

Die Bewertungen basieren auf Belastungstests in ähnlichen chemischen Gruppen.

* Alle Angaben in Grad Celsius



MATERIAL	NITRIL	SANTOPRENE®	PTFE	HYTREL®	NEOPRENE®	URETHAN	EPR/EPDM	VITON®	UHMW-PE	LEDER	POLYPROPYLEN	ACETAL	PVDF	ALUMINIUM	GUSSEISEN	ROSTFREI	HASTELLOY®
„Ammoniak, Gas, kalt“	B	A	A	D	A	B	A	D	A	X	B	A	D	X	X	X	X
„Ammoniak, wasserfrei“	B	A	A	D	A	X	A	D	A	D	A/70	D	D	A/70	A	A	A
„Anderol, L-774 (Di-Ester)“	X	X	A	X	D	D	D	A	X	X	X	X	X	X	X	X	X
L-826 (Di-Ester)	D	D	A	D	D	D	D	A	X	X	X	X	X	X	X	X	X
L-829 (Di-Ester)	D	D	A	D	D	D	D	A	X	X	X	X	X	X	X	X	X
„Chlor, nass“	D	C	A	D	D	D	A	A	B	D	D	D	A	D	B	B	A
„Chlor, trocken“	D	C	A	D	D	D	D	A/70	B	X	B	D	A	D	D	D	A
„Chlor, wasserfreie Flüssigkeit“	D	D	A	D	D	D	D	A	D	X	D	D	A	D	D	D	A
„Erdöl, roh“	C	C	A	A	B	A	D	A	A	X	B	A	A	X	X	X	X
„Estic 42, 43“	A	D	X	D	B	B	D	A	X	X	X	X	X	X	X	X	X
„Getriebeöl, Typ A“	X	C	A	B	B	A	D	A	X	X	X	A	X	A	A	A	A
„Kreosot, Holz“	D	D	A	D	C	C	D	A	D	X	D	D	X	X	X	B	X
„Kreosot, Kohlenteer“	D	D	A	D	D	D	D	A	D	X	D	D	X	B	B	B	B
„Lackverdünner, Duco“	D	C	A	X	D	D	D	B	X	A	D	A	X	A	A	A	X
„Lindol, Hydraulikflüssigkeit“	D	A	A	X	D	D	A	B	X	X	X	X	X	X	X	X	X
„Öle, roh (Asphalt-Basis)“	B	D	A	B	C	A	D	A	B	X	B	A	A	A	B	A	A
„Spelly, Lösungsmittel B,C,E“	X	X	A	X	D	X	D	A	X	X	X	X	X	X	X	X	X
„Teer, Bituminös“	B	B	A	B	C	B/70	D	A	X	X	A	A	X	A	X	A	A
„Wasser, destilliert“	A	A	A	X	B	A	A	A	A	A	A	A	A	B	D	A	A
„Wasser, frisch“	A	A	A	A	A	A	A	B	A	A	A	A	A	A	B	A	A
„Wasser, Salz“	A	A	A	A	A	B	A	A	A	A	A	A	A	D	D	C	X
„Wasser, saures Bergwerk“	A	A	A	X	C	C	A	A	A	X	A	A	A	D	D	A	A
„Wasser-Sole, Prozess, Getränke“	X	A	D	X	A	D	A	A	A	X	X	X	X	X	X	X	X
„Würze, Brennerlei“	X	X	X	X	B	B/70	A	A	X	X	X	X	X	A	B	A	A
0 - Chloronaphthalin	D	D	A	D	D	D	D	A	C	X	D	X	A	D	B	B	B
0 - Chlorphenol	C	C	A	X	D	D	D	B	X	X	X	B	A	C	C	A	A
1 - Chlorol 1 Nitro Ethan	D	C	A	D	D	D	D	D	X	X	D	X	X	D	X	X	X
40-100 % Lösung	X	C	A	D	A/140	D	A/130	A	B	X	A	D	A	D	D	B	A
Abwasser	A	A	A	A	A	D	A	A	A	X	A	A	A	B	B	A	A
Acetaldehyd (Ethanol)	D	B	A	B	D	D	A	D	B	B	C	A	D	B	A	A	A
Acetamid (Ethanamid)	A	A	A	D	B	D	A	A	A	X	A/70	A	A/75	A	A	A	A
Acetatlösemittel	D	B	A	D	D	D	A	D	B	X	B	A/70	A/70	A	D	A	A
Aceton	D	B	A	C	D	D	A	D	A	X	D	B	D	A	A	A	A
Acetonitril (Methylcyanid)	D	A/70	A	X	D	B	A	D	X	X	B/70	X	A/120	A	A	A	B
Acetophenon (Acetylbenzol)	D	B	A	X	D	X	B	D	X	X	B/70	X	A/70	B	A	A	B
Acetyl-Aceton	D	X	A	X	D	D	A	D	X	X	X	X	X	D	A	A	X
Acetylchlorid	D	B/70	A	D	D	D	D	B	D	X	D	X	A/120	D	A	B	A
Acetylen	A	X	A	A	B	D	A	A	X	A	D	A	A	A	A	A	A
Acetylsalicylsäure (Aspirin)	X	C	A	X	B	X	B	A	A	X	X	X	X	D	B	B	X
Acrolein (Acrylaldehyd)	X	A	A	D	D	D	A	B	X	X	X	X	X	B	B	B	X
Acrylnitril (Vinylcyanid)	D	D	A	D	D	D	D	C	X	X	B	X	A/70	A	A	A	A
Adipinsäure	B	B	A	D	A/140	X	A	A	A	X	A	A/70	A	B	B	B	A
Aero Lubriplate	A	C	A	D	A	X	D	A	X	X	A	A	A	A	A	A	A
Aero Shell 17 Schmiermittel	A	D	A	D	B	A	D	A	X	X	X	A	X	A	A	A	X
Aero Shell 1AC	A	D	A	D	B	B	D	A	X	X	A	A	B	A	A	A	A
Aero Shell 750	C	D	A	D	D	A	D	A	X	X	X	A	X	A	A	A	A

LEITFADEN

A = Ausgezeichnet, B = Gut, C = Mittel bis Schlecht, D = Nicht empfohlen

X oder Klammern um einen Bewertungsbuchstaben bedeuten, dass keine Daten verfügbar sind.

Die Bewertungen basieren auf Belastungstests in ähnlichen chemischen Gruppen.

* Alle Angaben in Grad Celsius



MATERIAL	NITRIL	SANTOPRENE®	PTFE	HYTREL®	NEOPRENE®	URETHAN	EPR/EPDM	VITON®	UHMW-PE	LEDER	POLYPROPYLEN	ACETAL	PVDF	ALUMINIUM	GUSSEISEN	ROSTFREI	HASTELLOY®
Aero Shell 7A Schmiermittel	A	D	A	D	B	D	D	A	X	X	X	A	X	A	A	A	X
Aerosafe 2300	D	B	A	A	D	A	A	D	X	X	X	A	X	A	A	A	X
Aerosafe 2300W	D	B	A	A	D	D	A	D	X	X	X	A	X	A	A	A	X
Ahornzuckerlikör (Saccharose)	A	A	A	X	A	D	A	A	X	X	X	X	X	X	X	X	X
Alkazene	D	D	A	D	D	D	X	A	B	X	X	X	X	X	X	X	X
Alkohol Amyl (1-Pentanol)	B	A	A	A	B	D	A	B	A	X	A	A	A	B/70	B	A	A
Alkohol Benzyl (Phenol Carbinol)	D	A	A	D	B	C	C	A	A	X	A/70	A/70	A	B/70	A	A	A
Alkohol Butyl (Butanol)	B	A	A	D	A	D	A	A	A	X	B	A	A	B	B	A	A
Alkohol Diaceton (Tyranton)	D	C	A	D	D	D	B	D	X	X	B	A	A/70	B	B	A	A
Alkohol Ethyl (Ethanol)	A	B	A	A	A	D	A	A	A	X	A	A	A	B/200	A	A	A
Alkohol Hexyl (1-Hexanol)	A	B	A	D	B	D	B	A	X	X	A/70	A	A	A	A	A	A
Alkohol Isopropyl (2-Propanol)	C	B	A	A	B	D	B	A	X	X	A	A	A/150	B	C	A	A
Alkohol Methyl (Methanol)	A	A	A	A	A	D	B	D	A	X	A/120	A	A	B	A	A	A
Alkohol Octyl (Caprylalkohol)	X	B	A	D	B	D	A	A	X	X	X	A	X	A	A	A	A
Alkohol Propyl (Propanol)	A	A	A	D	A	D	B	A	C	X	A	A	A/120	A	A	A	A
Allylalkohol	A	A	A	D	A	B	A	B	A	X	A	X	A	B	A	A	A
Allylbromid	D	X	A	D	D	A	D	B	X	X	X	X	X	D	A	X	X
Allylchlorid	C	X	A	D	D	D	D	B	B	X	A	X	A	D	C	B	X
Alum (Alum Kalium Sulfat)	A	A	A	D	A	D	A	A	A	X	A	A	A	C	D	B	B
Aluminiumacetat	X	A	A	X	B	D	A	D	A	X	A	A	X	A	D	B	B
Aluminium-Ammoniumsulfat	A	B	A	X	A/170	X	A	A	X	X	A	X	A	X	X	X	X
Aluminiumbromid	B	B	A	D	A	D	A	A	X	X	X	X	A	X	X	X	X
Aluminiumchlorid	A	A	A	B	A	B	A	A	A	X	A	B	A	B	D	C	A
Aluminiumfluorid	B	A	A	X	A	C/70	B	A	A	X	A	D	A	B	D	A	B
Aluminiumhydroxid	A	A	A	D	A	B	A	A	A	X	A	A	A	A	D	A	B
Aluminiumkaliumsulfat																	
Kaliumsulfat (Alum)	A	A	A	D	A	D	A	A	A	X	A	A	A	C	D	B	B
Aluminiumnitrat	A	A	A	X	A/70	C	A	A	A	X	A	B	A	B	D	A	B
Aluminiumphosphat	A	A	A	X	A	D	A	A	X	X	A	A	A	X	X	A	X
Aluminiumsulfat (Sulfat)	A	A	A	(B)	A	B	A	A	A	A	A	B/70	A	A	D	A	A
Ameisensäure	A	A	A	B	D	D	B	B	A	X	A	D	A	D	D	A	A
Amine	D	A	A	D	D	D	C	D	A	D	B/120	C/70	X	A	D	A	B
Ammoniak Flüssigkeiten	B	A	A	X	A	B	A	D	D	X	A/70	D	A	D	A	A	B
Ammonium Sulfid	X	X	A	X	A	B	A	D	A	X	X	X	X	X	X	X	X
Ammoniumacetat	A	A	A	D	A	D	A	A	A	X	A	C	X	B	A	X	X
Ammoniumbicarbonat	B	A	A	X	A	C	B	D	A	X	X	X	X	X	X	X	X
Ammoniumbifluorid	A	A	A	X	A	D	A	A	X	X	A	X	A	X	D	X	X
Ammoniumcarbonat	C	A	A	X	A	A	A	A	A	A	A	D	A	B	B	B	B
Ammonium-Casenit	X	A	A	X	A	X	X	X	X	X	X	A	X	X	X	A	X
Ammoniumchlorid 1 %	A	A	A	A/70	A	B/70	A	A	A	X	A	A	A	C	D	C	A
Ammoniumdichromat	B	A	A	X	A	X	A	X	X	X	X	X	X	A	A	X	X
Ammoniumdiphosphat	X	A	A	D	A	X	A	A	X	X	X	X	X	X	X	X	X
Ammoniumfluorid	B	B	A	X	B	X	A	A	A	X	A	X	A	D	D	D	A
Ammoniumhydroxid	B	A	A	(B)	A	D	A	B	A	B	A	B	A	B	B	B	A
Ammoniumnitrat	A	A	A	X	A	A	A	A	A	X	A	B	A	B	A	A	A
Ammoniumnitrat	A	A	A	X	C	B	A	D	X	X	A	B/70	A	C	A	A	B

LEITFADEN

A = Ausgezeichnet, B = Gut, C = Mittel bis Schlecht, D = Nicht empfohlen

X oder Klammern um einen Bewertungsbuchstaben bedeuten, dass keine Daten verfügbar sind.

Die Bewertungen basieren auf Belastungstests in ähnlichen chemischen Gruppen.

* Alle Angaben in Grad Celsius



MATERIAL	NITRIL	SANTOPRENE®	PTFE	HYTREL®	NEOPRENE®	URETHAN	EPR/EPDM	VITON®	UHMW-PE	LEDER	POLYPROPYLEN	ACETAL	PVDF	ALUMINIUM	GUSSEISEN	ROSTFREI	HASTELLOY®
Ammoniumnitrit	A	A	A	X	A	D	A	A	A	A	A/70	X	A	X	X	A	X
Ammoniumoxalat – 5 %-Lös.	B	A	A	X	A	X	A	X	A	X	X	B	X	X	D	A	A
Ammoniumpersulfatlös.	D	A	A	X	A	D	B	A	A	X	A	X	A	C	D	A	A
Ammoniumphosphat	A	A	A	B	A	B	A	A	B	X	A	B	A	B	D	A	A
Ammoniumsulfamat	A	A	A	B	A	A	A	A	X	X	X	X	X	X	X	X	X
Ammoniumsulfat 1 % - 5 %	A	X	A	C	A	B	X	D	A	X	A	A	A	B	C	A	B
Ammoniumsulfat	A	A	A	B	A	A	A	A	A	X	A	A	A	B	C	A	B
Ammoniumsulfid	A	A	A	X	A	D	A	A	D	X	A	D	X	C	D	B	A
Ammoniumthiocyanat	X	X	A	X	A	X	A	A	A	X	X	X	A	C	C	A	A
Ammoniumthiophosphat	A	A	A	D	A	X	A	A	X	X	X	X	X	X	X	X	X
Ammoniumthiosulfat	A	A	A	X	A	X	A	A	X	X	X	B	X	A	D	A	X
Amyl Chloranaphthalin	C	C	A	X	D	D	D	A	X	X	X	X	X	X	X	X	X
Amylacetat (Bananenöl)	D	D	A	C	D	D	A	D	B	B	B	D	A/120	B	X	A	B
Amylalkohol	B	A	A	A	A	D	A	A	A	X	B	A	A	B	C	A	B
Amylborat	X	B	A	X	A	D	D	A	X	X	X	X	X	X	X	X	X
Amylchlorid (Chlorpentan)	D	C	A	D	D	C	D	A	D	X	D	A	A	D	A	A	B
Amylnaphthalin	D	C	A	D	D	D	D	A	X	X	X	X	X	X	X	X	X
Amylphenol	X	C	A	X	X	X	X	A	X	X	X	X	X	A	A	A	A
AN-0-3 Grad M	B	B	A	D	D	B	B	A	X	X	X	X	X	X	X	X	X
AN-0-366	B	X	A	D	D	D	C	A	X	X	X	X	X	X	X	X	X
AN-0-6	B	X	A	D	A	D	A	A	X	X	X	X	X	X	X	X	X
ANG-25 (Di-Ester-Base) (TG7449)	D	D	A	X	D	D	D	A	X	X	X	X	X	X	X	X	X
ANG-25 (Glyzeraler Ester)	D	X	A	X	B	D	A	A	X	X	X	X	X	X	X	X	X
Anilin	D	A	A	C	D	D	D	D	C	X	A	A/70	A/70	C	C	A	B
Anilinfarbstoffe	D	B	A	D	B	D	A	A	C	X	X	D	X	B	A	B	X
Anilinhydrochlorid	D	A	A	X	D	D	B	B	C	X	D	X	A/100	D	D	D	X
Anilinöl	D	C	A	D	D	D	B	C	X	X	X	X	X	B	A	A	B
Anilinsulfid	X	X	X	X	X	X	X	X	X	X	X	X	X	X	X	C	X
Ansul Ether 161 oder 181	D	D	A	D	X	B	C	D	X	X	X	X	X	X	X	X	X
Anthracinon	D	D	A	D	D	B	C	D	X	X	X	X	X	B	B	B	A
Anti-Frost (Ethylenglykol)	A	A	A	A/70	A	B	A	A	A	X	A	B	A	B	B	A	A
Antimonchlorid	B	A	A	D	D	X	A	B	A	X	A	X	A	B	A	A	A
Antimontrichlorid	X	A	A	D	C	D	B	A	A	X	A	X	A	B	A	A	B
AN-VV-0-366b hydr. Flüssigkeit	D	D	A	D	C	D	D	A	X	X	X	X	X	X	X	X	X
Äpfelsäure	A	A	A	X	D	D	A	A	A	A	B	A	A	B	A	A	B
Äpfelsäure	B	A	A	X	B	X	D	A	X	A	B	A	A	B	D	A	B
Apfelwein (Apfelsaft)	B	A	A/122	D	A	D	A	A	A	X	X	A	X	B	D	A	A
Argon	A	A	A	A	D	A	A	A	X	X	X	X	X	X	X	X	X
Aroclor	D	D	A	C	D	B/70	B	A	X	X	D	X	X	A	B	A	A
Aromatische Kohlenwasserstoffe	D	C	A	C/70	D	D	D	A	X	X	D	A	X	A	A	A	X
Aromatischer Brennstoff 50 %	X	C	A	X	D	D	D	A	X	X	X	X	X	X	X	X	X
Arsensäure	A	A	A	D	B	C	A	A	X	B	A	D	A	D	D	A	B
Arsentrichlorid	B	B	A	D	A	X	D	A	A	X	X	D	X	D	D	D	B
Askarel	C	D	A	D	D	D	D	A	X	X	X	X	X	X	X	A	X
Ascorbinsäure	X	X	A	X	A	X	X	X	X	X	X	X	X	A	D	A	X
Asphalt	B	B	A	(B)	C	B	D	A	X	A	A	B	A	A	B	A	X

LEITFADEN

A = Ausgezeichnet, B = Gut, C = Mittel bis Schlecht, D = Nicht empfohlen

X oder Klammern um einen Bewertungsbuchstaben bedeuten, dass keine Daten verfügbar sind.

Die Bewertungen basieren auf Belastungstests in ähnlichen chemischen Gruppen.

* Alle Angaben in Grad Celsius



MATERIAL	NITRIL	SANTOPRENE®	PTFE	HYTREL®	NEOPRENE®	URETHAN	EPR/EPDM	VITON®	UHMW-PE	LEDER	POLYPROPYLEN	ACETAL	PVDF	ALUMINIUM	GUSSEISEN	ROSTFREI	HASTELLOY®
Asphalt-Belag	B	B	A	B	B	B	D	A	A	X	D	D	D	A	A	A	A
Asphaltemulsion	B	B	A	B	B	B	D	A	A	X	X	X	A	B	A	A	A
ASTM-Öl, NR. 1	C	C	A	A	B	B	D	A	A	X	X	A	X	A	A	A	A
B	B	C	A	A	D	D	D	A	X	X	X	X	X	A	A	A	A
C	C	D	A	A	D	D	D	A	X	X	X	X	X	A	A	A	A
Nr.2	X	C	A	A	B	D	D	A	A	X	X	A	X	A	A	A	A
Nr.3	C	C	A	A	C	D	D	A	A	X	X	A	X	A	A	A	A
Nr.4	X	X	A	D	D	D	D	A	A	X	X	A	X	A	A	A	A
ASTM-Referenzkraftstoff A	B	B	A	A	B	D	D	A	X	X	X	X	X	A	A	A	A
Atlantisches Dominion F	X	C	A	D	B	D	D	A	X	X	X	X	X	X	X	X	X
Aurex 903R (Mobil)	X	X	A	D	B	A	D	A	X	X	X	X	X	X	X	X	X
Automatikgetriebeöl	X	D	A	A	B	B	D	A	X	X	X	A	X	A	A	A	A
Bardol B	D	D	A	D	X	X	D	A	X	X	X	X	X	X	X	X	X
Bariumcarbonat	A	A	A	X	A	B	A	A	B	A	A	A	A	D	A	A	A
Bariumchlorid	A	A	A	X	A	A	A	A	B	X	A	A	A	D	D	B	A
Bariumcyanid	D	A	A	X	A	X	A	A	X	X	D	B	X	C	B	A	X
Bariumhydroxid (Bariumhydrat)	A	A	A	(B)	A	A	A	A	A	B	A	D	A	D	B	A	B
Bariumnitrat	A	A	A	X	A	B	A	A	B	X	A	B	A	B	A	A	A
Bariumsulfat	A	A	A	D	A	A	A	A	A	A	A	B	A	D	B	A	A
Bariumsulfid	A	A	A	X	A	A	A	A	B	A	A	A	A	D	D	B	A
Baumwollsamensöl	B	B	A	A/70	C	A/70	A/70	A	X	X	A	B	A	A	C	A	X
Bayol 35	D	D	A	X	A	X	D	A	X	X	X	X	X	X	X	X	X
Bayol D	D	D	A	X	A	X	D	A	X	X	X	X	X	X	X	X	X
Beizlösung	D	A	A	D	D	C	C/70	B/70	A	X	X	D	X	X	X	X	A
Benzaldehyd	D	D	A	B	D	D	A	D	C	X	D	A	A/70	A	A	A	A
Benzin (bleifrei)	C	C	A	X	D	D	D	A	B	X	D	A	A	A	A	A	A
Benzin (Luftfahrt)	D	C	A/170	A	D	C	D	A	C	A	D	A	A	X	X	X	X
Benzin (verbleit)	C	C	A	A	D	C	D	A	X	X	D	A	A	A	A	A	A
Benzoesäure	D	A	A	D	D	D	B	A	A	A	A	B	A	B	D	B	B
Benzol (Benzol)	C	C	A	B	D	D	D	B	D	B	B	A	A	B	B	B	A
Benzol (Benzol)	D	C	A	B	D	D	D	B	D	X	D	A	A/70	B	B	A	A
Benzolsulfonsäure	D	A	A	X	B	D	D	B	D	X	B/70	C	A	D	D	B	B
Benzyl Acetat	X	X	A	D	X	X	X	D	C	X	X	X	X	A	A	A	B
Benzylalkohol	D	D	A	C	C	D	C	A	A	X	A	X	A	A	A	A	B
Benzylbenzoat	X	C	A	D	D	D	B	A	X	X	X	X	X	A	B	B	B
Benzylchlorid (Chlortoluol)	D	C	A	D	D	D	D	A	A	X	D	A	A	D	D	B	A
Beschichtungslösungen																	
Antimon	B	A	A	X	A	X	X	A	A	X	A	A	A	D	A	A	A
Arsen	B	A	A	X	A	X	X	A	A	X	A	A	X	C	A	A	A
Blei	C	A	A	X	A	X	A	A	C	X	A	A	A	C	X	X	X
Bronze	B	A	A	X	A	X	A	A	A	X	A	B	X	C	A	A	A
Cadmium	B	A	A	X	A	X	A	A	A	X	A	C	A	C	A/70	A/140	A/90
Chrom	D	A	A	X	D	X	A	A	A	X	A	D	A	C	C	A	B
Eisen	B	A	A	X	A	X	X	A	A	X	A	X	A	C	X	A	A
Gold	B	A	A	X	A	X	A	A	A	X	A	X	A	C	X	A/150	A/70
Indium	B	A	A	X	A	X	X	A	A	X	A	X	X	C	X	A	A

LEITFADEN

A = Ausgezeichnet, B = Gut, C = Mittel bis Schlecht, D = Nicht empfohlen

X oder Klammern um einen Bewertungsbuchstaben bedeuten, dass keine Daten verfügbar sind.

Die Bewertungen basieren auf Belastungstests in ähnlichen chemischen Gruppen.

* Alle Angaben in Grad Celsius



MATERIAL	NITRIL	SANTOPRENE®	PTFE	HYTREL®	NEOPRENE®	URETHAN	EPR/EPDM	VITON®	UHMW-PE	LEDER	POLYPROPYLEN	ACETAL	PVDF	ALUMINIUM	GUSSEISEN	ROSTFREI	HASTELLOY®
Kupfer	B	A	A	X	A	D	A	X	A	X	A	X	A	C	A/70	A/150	A/120
Messing	B	A	A	X	A	X	A	A	A	X	A	A	A	C	A	A	A
Nickel	B	A	A	X	A	X	A	A	A	X	A	X	A	C	X	A/70	A/140
Silber	B	A	A	X	A	X	A	A	A	X	A	X	A	C	X	A	A
Zink	B	A	A	X	A	X	A	A	A	X	A	X	A	C	X	A	A
Zinn	B	A	A	X	A	X	A	A	A	X	A	X	A	C	X	A	A
Biphenyl (Diphenyl)	D	D	A	X	D	D	D	A	X	X	X	X	X	A	A	X	X
Bismutsubcarbonat	X	D	A	D	D	D	A	X	A	X	X	X	X	X	X	X	X
Bittersalz	A	A	A	X	A	X	A	A	A	X	A	B	A	A	A	A	B
Blausäure	D	A	A	D	B	D	A	A	A	X	A	D	A	A	D	A	A
Blei Nitrat	A	X	A	X	A	X	A	A	A	X	A	X	A	D	B	B	B
Bleiacetat	B	A	A	X	B	D	A	A	A	A	A	A	A	D	A	B	B
Bleichlorid	X	X	A	X	B	X	A	A	X	X	A	X	A	D	X	B	B
Bleichlösungen (Wasser, Chlor)	D	B	A	C	D	D	A	B	B	X	B	D	A	D	D	B	B
Bleisulfamat	A	A	A	X	A	X	A	A	X	X	A	A	A	C	X	X	X
Blut (Fleischsäfte - kalt)	D	B	A	D	A	D	A	C	X	X	A	X	X	A	D	A	X
Borax (Natriumborat)	A	A	A	A	A	A	A	A	A	A	A	A	A	C	A	A	A
Borbrennstoffe (HEF)	C	D	A	D	D	A	D	A	X	X	X	X	X	X	X	X	X
Bordeaux-Mischungen	B	A	A	B	A	D	A	A	A	X	X	X	X	D	C	A	A
Borsäure	A	A	A	A/70	A	A/70	A	A	A	A	A	C	A	B	D	A	A
Brauerei Slop	X	A	A	D	A	A	A	A	X	X	X	X	X	X	A	A	X
Bräunungsöle	X	X	A	X	D	X	X	A	A	X	A	D	A	A	X	A	A
Bremsflüssigkeit (Nicht-Petroleum)	D	A	A	D	B	A	A	D	A	X	D	X	X	A	A	A	A
Brom - wasserfrei	D	C	A	D	D	D	D	A	D	X	D	D	A/150	D	D	D	A
Brom	D	C	A	D	D	D	C	A	D	X	B/72	D	A/150	D	D	D	A
Brombenzol	D	D	A	D	D	D	D	B	D	X	D	D	A	D	B	B	B
Bromchlormethan	X	X	A	X	D	D	B	C	X	X	X	X	X	D	B	B	B
Bromchlortrifluorethan	X	D	A	X	D	D	D	A	X	X	X	X	X	X	X	X	X
Brom-Pentafluorid	D	D	A	X	D	D	D	D	X	X	X	X	X	X	X	X	X
Bromtoluol	X	X	A	X	X	X	X	B	X	X	X	X	X	D	A	A	A
Bromtrifluorid	D	C	A	D	D	D	D	D	X	X	D	D	X	D	D	B	X
Bromwasser	D	B	A	D	D	D	D	B	X	X	D	D	A	D	D	B	X
Bromwasserstoffsäure	D	B	A	X	D	X	A	X	A	X	B	D	A	D	D	D	A
Bronzing Flüssigkeit	X	A	A	X	D	D	B/70	D	X	X	X	X	X	X	X	A	A
Bunkeröl	B	B	A	D	D	D	D	A	A	X	X	X	X	A	A	A	A
Butadien (Monomer)	D	D	A	D	D	D	D	B	D	A	D	A	A	A	A	A	X
Butan (LPG) (Butylwasserstoff)	A	D	A	A	B	D	D	A	D	A	B	A	A	A	A	A	A
Butanol (Butylalkohol)	B	B	A	B	A	D	A	A	A	X	B	A	A	B	B	A	A
Butter	A	B	A	B	B	A	A	A	A	X	A	A	A	A	D	A	X
Buttermilch	A	A	A	X	A	A	A	A	A	A	A	A	A	A	D	A	A
Buttersäure	D	A	A	B	D	D	B	B	B	X	A	D	A	A	D	B	A
Buttersäureanhydrid	X	A	A	X	X	X	X	X	D	X	X	X	X	A	A	A	A
Butyl Cellosolve	D	A	A	X	D	D	A	D	X	X	X	A	B	X	X	X	X
Butylacetat	B	B	A	C	D	D	D	D	B	X	B/70	B	A	A	A	A	A

LEITFADEN

A = Ausgezeichnet, B = Gut, C = Mittel bis Schlecht, D = Nicht empfohlen

X oder Klammern um einen Bewertungsbuchstaben bedeuten, dass keine Daten verfügbar sind.

Die Bewertungen basieren auf Belastungstests in ähnlichen chemischen Gruppen.

* Alle Angaben in Grad Celsius



MATERIAL	NITRIL	SANTOPRENE®	PTFE	HYTREL®	NEOPRENE®	URETHAN	EPR/EPDM	VITON®	UHMW-PE	LEDER	POLYPROPYLEN	ACETAL	PVDF	ALUMINIUM	GUSSEISEN	ROSTFREI	HASTELLOY®
Butylacetylicinoleat	D	B	A	X	B/70	D	A/70	A/70	X	X	X	X	X	A	A	A	A
Butylacrylat	D	C	A	D	D	X	D	D	A	X	D	A	A/70	X	X	X	X
Butylalkohol (Butanol)	A	A	A	B	A	D	B	A	A	X	A/70	X	A	A	B	A	A
Butylamin (Aminobutan)	B	A	A	D	D	D	D	D	A	X	B	C	B/70	A	A	A	B
Butyläther (DiButylether)	X	C	A	X	B	X	X	C	A	X	D	X	A/100	A	A	A	X
Butylbenzoat	X	C	A	X	D	D	A	A	X	X	X	A	X	B	B	B	B
Butylbutyrat	X	C	A	D	D	X	A	X	X	X	X	X	X	A	A	A	A
Butylcarbitol	D	B	A	X	C	D	A	C	X	X	X	A	X	X	X	X	X
Butylchlorid (Chlorbutan)	D	D	A	X	C	X	X	A	X	X	D	X	A	A/70	A	A	A
Butylen (Buten)	C	C	A	B	C	C	C	A	X	X	B	A	A	A	X	A	X
Butyloleat	D	C	A	X	D	X	B	A	X	X	X	A	X	X	X	X	X
Butylstearat	C	C	A/70	X	D	B	D	A	A	X	X	A	A/100	B	B	B	B
Butyraldehyd	D	C	A	D	D	D	C	D	C	X	D	A	B	A	A	A	A
Butyronitril	X	X	A	D	D	X	A	C	X	X	X	X	X	X	X	X	X
Cadmiumsulfat (25 % Konzentration)	X	X	A	D	X	D	X	X	X	X	X	X	X	X	X	X	X
Cal. Hydrosulfid (Cal. Sulfhydrat)	X	A	A	X	A	X	A	A	A	X	X	X	X	X	X	X	X
Calciumacetat (Hydrat)	X	X	A	D	B	D	A	D	X	X	X	X	X	C	C	B	B
Calciumbisulfat	A	X	A	X	C	A	A	A	X	X	X	X	X	X	X	X	X
Calciumbisulfid	A	D	A	B	A	A	D	A	X	X	A	A	A	C	D	B	A
Calciumbisulfid	A	D	A	D	A	A	D	A	A	A	A	D	A	D	D	A	A
Calciumcarbonat (Kreide)	A	A	A	X	A	D	A	A	A	A	A	A	A	C	B	A	A
Calciumchlorat	A	A	A	X	A	B	A	A	A	X	A	X	A	B	B	B	B
Calciumchlorid (Sole)	A	A	A	A	A	A	A	A	A	X	A	D	A	C	C	C	A
Calciumhypochlorit	C	A	A	B	D	D	A	A	A	D	A	A	A	C	D	A	A
Calciumnitrat	C	A	A	X	B	D	B	A	A	X	A	D	A	B	C	B	B
Calciumoxid (ungeschälter Kalk)	A	A	A	B	A	B	A	A	A	X	X	X	X	A	A	A	A
Calciumsulfat	X	X	A	X	A	X	A	A	X	X	X	X	X	A	B	A	A
Calciumsulfat (Gips)	A	A	A	X	D	B	A	A	A	X	A	D	A	B	A	A	B
Calciumthiosulfat	C	A	A	D	A	A	A	A	X	X	X	X	X	X	X	X	X
Calgon	A	A	A	D	A	D	A	A	X	X	A	A	X	X	D	A	X
Caproischer Aldehyd	X	X	A	X	X	X	X	D	X	X	X	X	X	X	X	X	X
Caprylalkohol (Octanol)	B	A	A	X	D	D	A	B	X	X	X	X	X	A	A	A	A
Caprylsäure (Octansäure)	C	A	A	X	X	X	A	A	X	X	X	X	A	A	X	A	A
Carbamat	D	A	A	X	B	D	B	A	X	X	X	X	X	X	X	X	X
Carbitol	C	B	A	X	B	D	B	A	X	X	C	X	A	B	B	B	X
Carbolsäure (Phenol)	D	A	A	D	C	C	C	A	B	D	B	D	A/70	B	D	A	A
Catsup (Ketchup)	A	A	A	X	D	D	X	A	A	X	A	B	X	D	D	A	A
Cellosolve (Glykolether)	D	C	A	D	D	D	B	D	X	X	A	A	A	B	B	B	A
Cellosolve, Acetat	D	A	A	D	D	D	B	D	C	X	A	A	A/120	B	B	A	A
Cellosolve, Butyl	D	C	A	D	D	D	B	D	X	X	X	A	B	X	X	X	X
Celluguard	B	B	A	X	A	D	A	B	X	X	X	X	X	X	X	X	X
Cetan (Hexadecan)	B	D	A	D	B	D	D	A	X	X	X	X	X	X	X	X	X
China Holzöl (Tungöl)	B	B	A	B	A	C	D	A	X	X	A	A	A	A	A	A	A
Chinin Bisulfat (trocken)	D	X	A	X	A	A	A	A	A	X	D	D	D	D	D	B	A
Chinin Sulfat (trocken)	D	X	A	X	A	A	A	A	A	X	D	D	D	D	D	A	A

LEITFADEN

A = Ausgezeichnet, B = Gut, C = Mittel bis Schlecht, D = Nicht empfohlen

X oder Klammern um einen Bewertungsbuchstaben bedeuten, dass keine Daten verfügbar sind.

Die Bewertungen basieren auf Belastungstests in ähnlichen chemischen Gruppen.

* Alle Angaben in Grad Celsius



MATERIAL	NITRIL	SANTOPRENE®	PTFE	HYTREL®	NEOPRENE®	URETHAN	EPR/EPDM	VITON®	UHMW-PE	LEDER	POLYPROPYLEN	ACETAL	PVDF	ALUMINIUM	GUSSEISEN	ROSTFREI	HASTELLOY®
Chloracetaldehyd	X	X	A	X	D	D	A	D	X	X	X	X	X	X	X	X	X
Chloraceton	D	C	A	D	C	D	D	B	X	X	D	B	X	D	B	B	B
Chlorat des Kalkes	D	D	A	D	D	D	A	A	A	X	X	X	X	X	X	X	X
Chlorbenzol (Konzentration: Rein)	D	D	A	X	D	X	D	D	X	X	X	X	X	X	X	X	X
Chlorbenzol	C	C	A	D	D	D	D	A	B	X	B	A	A/70	D	B/70	B	A
Chlorbrommethan	D	D	A	D	D	D	B	A	D	X	D	B	X	D	B	B	X
Chlorbutadien	D	C	A	D	D	D	D	A	X	X	D	X	X	D	B	A	B
Chlordioxid	D	D	A	D	D	D	C	B	D	X	D	X	A	D	D	D	A
Chloressigsäure	C	D	A	X	D	D	B	D	D	X	X	X	X	X	X	X	X
Chloretol	X	X	A	X	B	D	D	A	X	X	X	X	X	X	X	X	X
Chloriertes Wasser - Gesättigt	D	D	A	D	C	D	D	A	A	X	B	D	A	C	X	B	A
Chlorkalk - 35 % (Bleichmittel)	C	A	A	C	D	D	A	A	A	X	B	D	A	D	D	A	A
Chlorodan	D	C	A	D	D	D	D	A	X	X	X	X	X	X	X	X	X
Chlorododecan	D	D	A	D	D	D	D	A	X	X	D	X	X	D	D	X	X
Chloroform	C	C	A	C	D	D	D	A	D	X	D	A	A	D	D	A	B
Chlorsulfonsäure (nass)	D	D	A	D	D	D	D	D	D	X	C	D	C	D	D	D	B
Chlorsulfonsäure (trocken)	C	C	A	C	D	D	C	C	D	X	C	D	C	D	D	D	B
Chlortoluol	D	C	A	D	D	D	D	A	X	X	D	A	X	D	B	B	A
Chlortrifluorid	D	D	A	X	D	D	D	D	D	X	D	X	X	D	D	A	X
Chlorwasserstoffgas	B	B	A	X	B	X	A	A	X	X	A/140	X	A	D	A	A	A/125
Chromsäure - 5 %	D	A	A	D	D	D	A	A	A	X	A/70	D	A	C	D	A	A
Chromsäure - 50 %	D	A	A	D	D	D	C	A	A	X	B/140	D	A	C	D	B	A
Citrus Pektin Liquor	B	X	A	B	A	C	X	C	D	X	X	X	X	X	X	A	X
Coca Cola Sirup	B	A	A	X	B	B	A	B	X	X	X	X	X	X	X	X	X
Coliche-Liköre	B	B	A	X	A	X	B	X	X	X	X	X	X	X	X	X	X
Convelex 10	D	D	A	D	D	D	X	A	X	X	X	X	X	X	X	X	X
Coolanol (Monsanto)	B	D	X	X	B	D	D	A	X	X	X	A	A	D	D	C	B
Cresylsäure (Cresol)	D	B	A	D	D	D	D	A	D	X	C	D	A/150	C	A	A	B
Crotonaldehyd	X	B	A	X	D	D	A	D	X	X	X	X	X	A	A	A	A
Cumol (Isopropylbenzol)	D	D	A	X	D	D	D	A	A	X	X	X	X	B	B	B	B
Cyan säure	D	B	A	X	D	D	A	D	A	X	X	D	X	X	D	A	X
Cyanwasserstoffgas	A	A	A	D	D	D	A	A	X	X	A	X	A	D	A	B	X
Cyclohexan	A	C	A	A	D	B	D	A	A	X	C/70	A	A	A	B	A	B
Cyclohexanol	C	D	A	X	A	B	C	A	A	X	B/70	A	A/150	C	B	B	A
Cyclohexanon	D	D	A	D	D	D	C	D	B	X	D	A	B70	B	B	B	B
Decalin	D	C	A	X	D	D	D	A	C	X	B/120	X	A/175	X	X	X	X
Decanal	X	D	A	X	D	X	D	D	X	X	X	X	X	X	X	X	X
Decylalkohol (Decanol)	X	X	A	X	D	D	X	B	X	X	X	X	X	X	X	X	X
De-ionisiertes Wasser	A	A	A	A	A	X	A	A	A	X	A	X	A	A	C	A	A
Dekan	A	B	A	X	D	B	D	A	X	X	A/70	X	A	X	X	X	X
Denaturierter Alkohol	A	B	A	X	A	D	A	B	X	X	A	A	A	A	A	A	A
Dextron	C	D	A	X	B	B	D	A	X	X	X	X	X	X	X	X	X
Diacetonalkohol (Diacetol)	D	B	A	C	D	D	A	D	X	X	B	A	A/70	A	A	A	A
Diamylamin	X	B	A	X	D	D	A	D	X	X	X	X	X	X	X	X	X
Diazinon	D	D	A	D	C	D	D	B	X	X	X	X	X	X	X	X	X

LEITFADEN

A = Ausgezeichnet, B = Gut, C = Mittel bis Schlecht, D = Nicht empfohlen

X oder Klammern um einen Bewertungsbuchstaben bedeuten, dass keine Daten verfügbar sind.

Die Bewertungen basieren auf Belastungstests in ähnlichen chemischen Gruppen.

* Alle Angaben in Grad Celsius



MATERIAL	NITRIL	SANTOPRENE®	PTFE	HYTREL®	NEOPRENE®	URETHAN	EPR/EPDM	VITON®	UHMW-PE	LEDER	POLYPROPYLEN	ACETAL	PVDF	ALUMINIUM	GUSSEISEN	ROSTFREI	HASTELLOY®
Dibenzylether	X	C	A	X	D	B	C	C	X	X	X	X	C	B	B	B	B
Dibenzylsebacat	D	C	A	X	D	B	B	B	X	X	X	X	X	X	X	X	X
Dibromethylbenzol	D	C	A	X	D	D	D	A	X	X	X	X	X	X	X	X	X
Dibutylamin	D	C	A	X	D	D	D	B	X	X	D	X	B	X	X	X	X
Dibutylether	D	B	A	X	D	D	C	C	X	X	X	X	X	X	X	X	X
Dibutylphthalat	B	B	A	A	D	C	A	B	A	A	B	X	D	A	A	A	A
Dibutylsebacat	D	B	A	A	D	D	B	B	X	X	B/72	X	D	X	A	A	X
Dichlorbutan	X	X	A	X	D	D	D	A	X	X	X	X	X	D	B	B	X
Dichloressigsäure	X	B	A	X	D	X	C	D	X	X	X	X	X	X	X	X	X
Dichlorethan	D	D	A	D	D	D	D	B	C	X	A	A	A/70	X	D	A	B
Dichlorethylether	X	X	A	X	X	X	X	X	X	X	X	X	X	B	X	X	X
Dichlor-Isopropylether	D	D	A	D	D	B	C	C	X	X	D	X	X	D	X	X	X
Dichlorpentan	D	D	A	X	D	D	D	A	X	X	X	X	X	X	X	X	X
Dicyclohexylamin	D	B	A	X	D	D	D	D	X	X	X	X	X	X	X	X	X
Dieselöl (Kraftstoff ASTM # 2)	B	D	A	B	D	B	D	A	D	X	B/70	A	A	A	A	A	A
Di-Ester Schmierstoff Mil-L-7808	C	D	A	X	D	D	D	A	X	X	X	X	X	X	X	X	X
Di-Ester synthetische Schmiermittel	D	D	A	D	D	D	D	A	X	X	X	X	X	A	A	A	A
Diethanolamin	D	X	A	D	D	D	A	D	X	X	A	X	X	A	A	A	A
Diethyl Anilin	D	B	A	X	D	D	B	C	X	X	A	X	A	X	X	X	X
Diethylamin	D	C	A	X	B	C	B	D	X	X	A	X	A/70	B	D	B	X
Diethylbenzol	D	C	A	X	D	D	D	A	D	X	X	X	X	X	X	X	X
Diethylcarbonat	D	D	A	X	D	D	D	A	X	X	X	X	X	X	X	X	X
Diethylenether (Dioxan)	D	D	A	X	X	X	D	X	X	X	X	X	X	A	A	A	X
Diethylen glycol	A	A	A	A	A	D	A	A	A	X	A	D	X	A	A	A	A
Diethylentriamin	D	B	A	X	D	D	A	D	X	X	X	X	X	A	A	A	A
Diethylether	D	B	A	C	D	A	D	D	D	X	D	A	A/70	B	B	B	B
Diethylformamid	C	A	A	B	D	D	B	D	A	X	A/120	C	D	A	A	A	A
Diethylphthalat (Dep)	B	A	A	A	X	X	X	C	X	X	X	X	X	A	A	A	A
Diethylsebacat	B	B	A	A	D	D	B	A	X	X	A/120	X	A/120	A	A	A	A
Diethylsulfat	D	B	A	X	A	D	A	D	X	X	X	X	X	X	X	X	X
Difluordibrommethan	D	B	A	D	D	D	B	X	X	X	X	X	X	X	X	X	X
Diisobutylen	C	C	A	D	C	D	D	A	A	X	A/120	A	A	B	B	B	X
Diisobutylketon	D	B	A	X	D	D	A	D	X	X	X	X	X	A	A	A	A
Diisodecyladipat (D10A)	X	X	A	X	X	X	X	C	X	X	X	X	X	X	X	X	X
Diisodecylphthalat (D10P)	X	X	A	X	D	X	A	C	X	X	X	X	X	X	X	X	X
Diisooctyladipat (D10A)	X	X	A	X	X	X	X	C	X	X	X	X	X	A	A	A	A
Diisooctylphthalat (D10P)	D	C	A	X	X	X	B	C	X	X	X	X	X	X	X	X	X
Diisooctylsebacat	D	D	A	X	D	D	C	B	X	X	X	X	X	X	X	X	X
Diisopropylamin	C	X	A	X	X	X	X	X	X	X	X	X	X	X	X	X	X
Diisopropylbenzol	D	C	A	D	D	D	D	A	X	X	X	A	X	X	X	X	X
Diisopropylketon	D	C	A	X	D	D	A	D	X	X	X	A	A	X	X	A	X
Dimethylanilin	D	B	A	X	D	D	B	C	A	X	A	D	A/70	A	X	X	B
Dimethylphthalat	D	A	A	A	D	D	B	A	X	X	A	X	A/70	A	A	A	A
Dipenten	C	C	A	X	D	D	D	A	X	X	X	X	X	A	A	A	A
Diphenyl	D	C	A	X	D	D	D	A	X	X	X	X	A/120	A	A	A	A

LEITFADEN

A = Ausgezeichnet, B = Gut, C = Mittel bis Schlecht, D = Nicht empfohlen

X oder Klammern um einen Bewertungsbuchstaben bedeuten, dass keine Daten verfügbar sind.

Die Bewertungen basieren auf Belastungstests in ähnlichen chemischen Gruppen.

* Alle Angaben in Grad Celsius



MATERIAL	NITRIL	SANTOPRENE®	PTFE	HYTREL®	NEOPRENE®	URETHAN	EPR/EPDM	VITON®	UHMW-PE	LEDER	POLYPROPYLEN	ACETAL	PVDF	ALUMINIUM	GUSSEISEN	ROSTFREI	HASTELLOY®
Diphenyloxide	D	C	A	X	D	D	D	A	X	X	X	D	A	B	A	A	B
Dipropylamin	X	X	A	X	X	X	X	X	X	X	X	X	X	X	X	X	X
Dipropylenglycol	A	A	A	X	X	X	X	A	X	X	A	X	A	X	X	X	X
Dipropylketon (Butyron)	D	X	A	D	X	X	X	D	X	X	X	X	X	X	X	X	X
Divinylbenzol (DVB)	D	D	A	X	D	X	D	A	X	X	X	X	X	X	X	X	X
Dodecylbenzol (Alkane)	D	X	A	X	X	X	X	A	X	X	X	X	X	A	A	A	X
Dow (Silicone)	A	A	A	B	A	A	A	A	X	X	X	X	X	A	X	X	X
Dowtherm A	D	D	A	B	D	D	D	A	X	X	B	X	X	C	B	A	X
Dowtherm E	D	D	X	B	D	D	D	A	X	X	B	X	X	X	X	X	X
DTE Leichtöl	B	D	B	B	B	D	D	A	A	X	X	X	X	X	X	X	X
Eisen (III) sulfat	A	A	A	A	A	A	A	A	A	X	A	B	A	D	D	A	A
Eisenchlorid	A	A	A	B/140	A/140	A/70	A/176	A/176	D	A	A	X	A	D	D	D	B
Eisenchlorid	B	A	A	A	A	D	A	A	A	X	A	B	A	D	D	D	B
Eisenhydroxid	B	B	A	X	B	X	B	B	X	X	X	X	X	X	X	A	B
Eisennitrat	A	A	A	D	B	A/70	A	A	A	A	A	A	A	D	D	A	A
Eisensulfat (Copperas)	A	A	A	A	A	A	A	A	A	X	A	B/70	A	D	D	A	B
Eisessig	D	A	A	D	D	D	A	D	X	X	X	X	X	X	X	X	X
Entfettungsflüssigkeit (chloriert)	D	D	A	X	D	A	D	A	X	X	X	X	X	X	X	X	X
Entwicklungsflüssigkeiten (Foto)	X	A	A	D	A	D	B	A	A	X	X	A	X	X	D	A	A
Epichlorhydrin	D	B	A	D	D	D	C	D	X	X	A	A	C	D	A	A	A
Erdgas	A	C	A	B	A	C	D	A	X	X	A	A	X	A	A	A	X
Erdnussöl	A	B	A	X	A	B/70	C/70	A	A	X	A	X	A	X	A	A	A
Esam-6 Flüssigkeit	X	B	X	X	B	X	A	D	X	X	X	X	X	X	X	X	X
Essig	B	A	A	C	B	B	A	A	A	A	A	B	A	D	C	A	A
Essigsäure	C	B	A	D	C	C	A	C	B	D	B	D	A	B	D	A	A
Essigsäureanhydrid	D	A	A	C(B)	B	D	B	D	D	B	C	D	D	B	D	A	A
Ethan	C	C	A	X	B/70	B/70	D	A	X	X	C	A	X	A	A	A	A
Ethanol (Ethylalkohol)	A	A	A	A	A	D	A	A	A	X	A	A	A	B	A	A	A
Ethanolamin (Aminoethanol)	B	A	A	X	B	C	B	D	A	X	B	D	C	B	B	A	B
Ethanolchlorid	D	B	A	X	D	X	C	B	X	X	X	X	X	X	X	X	X
Ether	D	C	A	X	D	D	C	D	D	A	C	A	A/70	A	C	A	B
Ethyl Cellosolve	C	B	A	X	D	D	B	D	X	X	X	A	X	X	X	X	X
Ethyl Hexyl Alkohol (Ethylhexanol)	A	A	A	D	A	D	A	A	X	X	X	X	X	A	A	A	A
Ethyl Mercaptan	D	C	A	X	D	A	D	B	X	X	X	X	X	B	A	B	B
Ethyl Oxalat	D	B	A	D	D	A	A	B	X	X	X	X	X	A	X	X	X
Ethylacetat	D	A	A	B	D	D	B	D	B	X	A	A/120	A	B	A	A	B
Ethylacetoacetat	D	B	A	D	D	D	A	D	A	X	X	A	A/70	A	A	A	A
Ethylacrylat	D	C	A	X	D	D	B	D	X	X	D	A	C	A	A	A	A
Ethylacrylsäure	D	C	A	X	B	D	B	D	X	X	X	X	X	X	X	X	X
Ethylalkohol (Ethanol)	A	A	A	A	A	D	A	A/70	A	X	A	X	A	B	B	A	A
Ethylaluminiumdichlorid	D	X	A	X	X	X	X	B	X	X	X	X	X	X	X	X	X
Ethylamin (Monoethylamin)	X	X	A	X	D	D	A	D	X	X	X	X	X	B	B	A	X
Ethylbenzoat	D	C	A	X	D	D	D	A	X	X	B/70	A	X	A	A	A	A
Ethylbenzol	D	D	A	X	D	D	D	A	A	X	D	A	C	A	B	B	A
Ethylbromid	C	X	A	X	D	D	D	A	X	X	D	X	X	A	A	A	X

LEITFADEN

A = Ausgezeichnet, B = Gut, C = Mittel bis Schlecht, D = Nicht empfohlen

X oder Klammern um einen Bewertungsbuchstaben bedeuten, dass keine Daten verfügbar sind.

Die Bewertungen basieren auf Belastungstests in ähnlichen chemischen Gruppen.

* Alle Angaben in Grad Celsius



MATERIAL	NITRIL	SANTOPRENE®	PTFE	HYTREL®	NEOPRENE®	URETHAN	EPR/EPDM	VITON®	UHMW-PE	LEDER	POLYPROPYLEN	ACETAL	PVDF	ALUMINIUM	GUSSEISEN	ROSTFREI	HASTELLOY®
Ethylbutylacetat	D	X	A	X	X	X	X	D	X	X	X	X	X	X	X	X	X
Ethylbutylalkohol	A	X	A	D	X	D	X	B	X	X	X	X	X	X	X	X	X
Ethylbutylketon	D	X	A	X	X	X	X	D	X	X	X	X	X	X	X	X	X
Ethylbutyraldehyd	D	X	A	X	X	X	X	D	X	X	X	X	X	X	X	X	X
Ethylbutyrat	D	X	A	X	D	X	D	C	C	X	B/70	X	X	B	A	A	A
Ethylcaprylat	D	X	A	X	D	X	D	X	X	X	X	X	X	X	X	X	X
Ethylchlorcarbonat	D	A	A	D	D	D	D	A	X	X	X	A	X	D	A	X	X
Ethylchlorformiat	D	C	A	D	D	D	D	A	X	X	D	A	X	D	X	X	X
Ethylchlorid	C	D	A	C	D	C	A/140	A	D	X	D	A	A	D	C	A	B
Ethylcyanid (Propionitril)	D	X	A	X	B	X	A	D	X	X	X	X	X	X	X	X	X
Ethylcyclopentan	X	X	X	X	C	A	D	A	X	X	X	X	X	X	X	X	X
Ethylen (Ethen)	B	C	A	D	C	B	D	A	X	X	X	A	X	A	A	A	X
Ethylen-Chlorhydrin	D	C	A	D	B	D	B	A	X	X	D	C/70	A/70	B	B	B	X
Ethylenchlorid	D	D	A	C	D	D	C	C	C	X	C/70	A	A	B	C	A	B
Ethylendiamin	B	A	A	X	A	D	A	D	A	X	A	A	B/70	A	A	A	C
Ethylendibromid	D	D	A	X	D	D	D	A	X	X	B/70	X	A	D	B	A	B
Ethylendichlorid	C	C	A	C	D	D	D	B	D	A	D	A	A	B	A	A	A
Ethylenglykol	A	A	A	A/70	A	B	A	A	A	X	A	B	A	B	B	A	A
Ethylenoxid	A	A	A	A	D	D	B	D	X	X	C/125	A	A/70	D	C	A	X
Ethylentrichlorid	X	X	A	X	D	D	D	A	X	X	D	X	A	D	A	A	X
Ethylether	D	D	A	X	D	D	D	D	D	X	C/70	A/70	B/170	B	B	A	B
Ethylformiat	D	B	A	D	B	X	B	A	C	X	X	A	X	C	A	B	B
Ethylhexylacetat	X	X	A	D	X	X	X	D	X	X	X	X	X	X	X	X	X
Ethylidenchlorid	D	D	A	X	D	X	D	X	X	X	X	X	X	D	B	A	B
Ethyljodid	X	X	A	X	D	X	C	B	X	X	X	X	X	X	X	X	X
Ethylisobutyrat	X	X	A	X	D	X	D	X	X	X	X	X	X	X	X	X	X
Ethylpentachlorbenzol	D	D	A	X	D	C	D	A	X	X	D	X	X	D	X	X	X
Ethylpropionat	D	D	A	D	D	X	D	X	X	X	X	X	X	A	A	A	A
Ethylsilikat	B	B	A	B	A	D	A	A	X	X	X	X	X	B	A	A	A
Ethylsulfat	D	B	A	X	A	D	A	D	X	X	X	X	X	X	X	D	X
Ethylzellulose	B	A	A	B	B	B	B	D	X	X	X	A	X	B	A	B	B
Fett (Erdölbasis)	A	D	A	A	D	A	D	A	X	X	A	A	A	A	A	A	A
Fett (Esterbasis)	C	B	A	X	X	X	X	X	X	X	A	A	A	A	A	A	A
Fett (Silikonbasis)	A	B	A	X	X	X	X	X	X	X	A	A	A	A	A	A	A
Fettsäuren	B	B	A	D	B/70	D	D	A	A	A	B/140	B	A	B	D	A	A
Fischöl	A	B	A	B	B	B	D	A	A	X	X	X	X	X	X	X	X
Flugbenzin, Mil.	B	X	A	D	C	D	D	A	X	X	X	X	X	A	A	A	A
Fluor (wasserfrei)	D	D	B	D	D	D	D	B	X	X	D	A	A/70	D	D	A	B
Fluorbenzol	D	C	A	X	D	X	D	A	X	X	D	A	X	D	X	X	X
Fluorborsäure	A	A	A	D	A	D	A	A	A	X	A	X	A	D	D	B	A
Fluorchlorethylen	D	C	A	X	D	X	D	A	X	X	X	X	X	X	X	X	X
Fluorierte cyclische Ether	D	D	A	X	D	X	A	A	X	X	X	X	X	X	X	X	X
Fluorkieselsäure	A	A	A	B	A	B	B	A/140	A	X	A	X	A	D	D	B	B
Fluorcarbon-Öl	D	D	A	X	A	X	A	X	X	X	D	X	X	D	A	A	A
Fluorolube (Fluorcarbonöl)	X	X	A	D	A	X	A	B	X	X	D	X	X	A	A	A	A

LEITFADEN

A = Ausgezeichnet, B = Gut, C = Mittel bis Schlecht, D = Nicht empfohlen

X oder Klammern um einen Bewertungsbuchstaben bedeuten, dass keine Daten verfügbar sind.

Die Bewertungen basieren auf Belastungstests in ähnlichen chemischen Gruppen.

* Alle Angaben in Grad Celsius



MATERIAL	NITRIL	SANTOPRENE®	PTFE	HYTREL®	NEOPRENE®	URETHAN	EPR/EPDM	VITON®	UHMW-PE	LEDER	POLYPROPYLEN	ACETAL	PVDF	ALUMINIUM	GUSSEISEN	ROSTFREI	HASTELLOY®
Fluorsulfonsäure	X	X	X	X	X	X	X	X	X	X	X	X	X	X	X	X	X
Fluorwasserstoff	D	X	B/70	D	X	D	B/70	A	X	X	A/70	X	X	D	X	D	A
Fluorwasserstoffsäure 20 %	D	D	A	D	D	D	B	A	X	X	A	D	A	D	D	D	D
Fluorwasserstoffsäure 50 %	D	D	A	D	D	D	B	A	X	X	B/70	D	A	D	D	D	D
Fluorwasserstoffsäure 75 %	D	D	A	D	D	D	D	D	X	X	B/70	D	A	D	D	D	D
Fluorwasserstoffsäure konzentriert	D	D	A	D	D	D	D	D	A	X	D	D	A	D	D	D	D
Flüssiger Sauerstoff	D	X	A	X	D	D	D	D	X	X	X	X	X	X	X	X	X
Flüssiggas (LPG)	D	C	A	B	C	C	D	A	X	X	D	A	X	X	X	X	A
Formaldehyd	A	A/70	A	B	B	D	A	A	A	X	A	A	A	A	D	A	B
Formamid	A	A	A	D	A	X	A	D	X	X	X	X	X	A	B	B	B
Fotografischer Entwickler	B	A	A	D	A	B	B	A	A	X	A	A	A	C	D	A	A
Freon 11	C	B	A	A	B	D	D	C	X	X	D	A	A	C	A	A	A
Freon 112	B	X	A	X	B	B/70	D	A	X	X	X	A	X	D	X	X	X
Freon 113	D	D	A	A	A	B	D	B	X	X	D	A	A	D	X	A	A
Freon 114	B	X	A	A	A	A/70	D	A	X	X	D	A	A	C	X	A	X
Freon 12	C	D	A	A	A	A/130	B	B	X	X	B	A	A	A	A	A	A
Freon 13	D	X	A	C	A	C/70	A	A	X	X	D	A	A	A	A	A	A
Freon 13BI	D	X	A	X	A	A	A	A	X	X	X	X	X	X	X	X	X
Freon 14	A	X	A	X	A	A/170	A	A	X	X	X	X	X	X	X	X	X
Freon 142b	X	X	A	X	A	X	A	D	X	X	X	A	X	D	X	X	X
Freon 152a	X	X	A	X	A	X	A	D	X	X	X	A	X	D	X	X	X
Freon 152a	X	X	X	X	X	X	X	X	X	X	X	A	X	C	X	X	X
Freon 21	D	X	A	X	D	X	D	D	X	X	D	A	A	D	X	X	X
Freon 218	X	X	A	X	A	X	X	A	X	X	X	A	X	D	X	X	X
Freon 22	D	D	A	D	A	D	A	D	X	X	D	A	A	D	D	A	A
Freon 31	D	X	A	X	A	X	A	D	X	X	X	A	X	D	X	X	X
Freon 32	D	X	A	X	A	X	A	D	X	X	X	A	X	D	X	X	X
Freon 502	X	X	A	D	A	X	A	B	X	X	X	A	X	D	X	X	X
Freon C316	X	X	A	X	A	X	A	A	X	X	X	A	X	D	X	X	X
Freon C318	X	X	A	X	A	X	A	A	X	X	X	A	X	D	X	X	X
Freon K-142B	X	X	X	X	X	X	X	X	X	X	X	A	X	D	X	X	X
Freon K-152a	X	X	X	X	X	X	X	X	X	X	X	A	X	D	X	X	X
Freon TA	X	X	A	X	A	A	A	C	X	X	X	X	X	D	X	X	X
Freon TC	X	X	A	X	A	A	B	A	X	X	X	X	X	D	X	X	X
Freon TMC	X	X	A	A	B	B	B	A	X	X	X	X	X	D	X	X	X
Freon T-P35	X	X	A	X	A	A	A	A	X	X	X	X	X	D	X	X	X
Freon T-WD602	X	X	A	X	B	A	B	A	X	X	X	X	X	D	X	X	X
Freon, BF	X	X	A	X	B	X	D	A	X	X	X	X	X	D	X	X	X
Freon, MF	X	X	A	A	D	D	D	D	X	X	X	X	X	D	X	X	X
Freon, PCA	X	X	X	X	A	A	D	B/70	X	X	X	X	X	D	X	X	X
Freon, TF	X	D	A	A	A	B	D	B	X	X	X	A	B	D	A	A	A
Freon114B2	X	X	A	X	A	X	D	B	X	X	X	X	X	X	X	X	X
Fumarsäure (Boletic Acid)	X	A	A	B	B	X	B	A	C	X	X	X	X	X	X	X	X
Furan (Furfuran)	D	A	A	X	D	X	D	D	X	X	C	X	D	A	A	A	X
Furfural (Ameisenöl)	D	A	A	B	C	D	A	D	B	X	D	B	B/120	A	B	A	B
Furfurylalkohol	D	C	A	B	D	D	B	D	X	X	X	X	B/100	A	A	A	A

LEITFADEN

A = Ausgezeichnet, B = Gut, C = Mittel bis Schlecht, D = Nicht empfohlen

X oder Klammern um einen Bewertungsbuchstaben bedeuten, dass keine Daten verfügbar sind.

Die Bewertungen basieren auf Belastungstests in ähnlichen chemischen Gruppen.

* Alle Angaben in Grad Celsius



MATERIAL	NITRIL	SANTOPRENE®	PTFE	HYTREL®	NEOPRENE®	URETHAN	EPR/EPDM	VITON®	UHMW-PE	LEDER	POLYPROPYLEN	ACETAL	PVDF	ALUMINIUM	GUSSEISEN	ROSTFREI	HASTELLOY®
Furylcarbinol	D	X	A	X	D	D	B	D	X	X	X	X	X	X	X	X	X
Fuselöl (Getreideöl)	X	X	A	X	B	C/70	A	A	X	X	X	X	X	X	X	X	X
Gallussäure	D	B	A	D	B	D	B	A	A	A	A	X	A/70	A	D	B	B
Gehäuse Kopf Gas	X	X	A	X	A	X	X	X	X	X	X	X	X	X	X	X	X
Gelatine	A	A	A	B	A	D	A	A	A	X	A	B	A	A	D	A	A
Gemüsesäfte	X	A	D	X	B	B	A	A	X	X	X	A	X	C	X	A	X
Gerbsäure	A	A	A	A	A	A	A	A	A	X	A	D	A	D	C	A	B
Glaubersalz	X	X	A	B	A	A	B	A	A	X	X	X	X	X	X	X	X
Glucose (Maissirup)	A	A	A	B	A	A	A	A	A	A	A	A	A	A	B	A	A
Glycerin - Glycerol	A	A	A	A	A	D	A	A	A	A	A	A	A	A	B	A	A
Glykolsäure	A	X	A	X	A	X	X	A	A	X	A	A	A/70	X	X	X	A
Grapefruit-Öl	X	A	A	X	D	X	X	A	X	X	X	X	X	X	D	A	X
Grubenwasser	A	B	A	X	C	D	A	A	A	X	A	A	A	A	A	A	A
Grüner Sulfat-Alkohol	B	A	A	D	B	A	A	A	A	X	A	X	X	B	C	A	B
Halothan	D	X	X	X	D	D	X	A	X	X	X	X	X	X	X	X	X
Halowax Öl	D	D	A	X	D	X	D	A	X	X	X	X	X	D	X	X	X
Hannifin Lube A	A	D	X	X	A	A	D	A	X	X	X	X	X	X	X	X	X
Harnsäure	X	X	A	D	X	D	X	X	X	X	D	D	D	D	X	B	B
Harnstoff (Carbamid)	B	A	A	B	A	B	A	A	A	X	A	A	A	B	X	B	B
HEF - 2 (Hochenergiekraftstoff)	B	D	X	X	A	D	D	A	X	X	X	X	X	X	X	X	X
Heizöl	B	C	A	B	A	D	D	A	D	A	A	B	A	A	A	A	A
Helium	A	A	A	X	A	A	A	A	X	X	A	A	X	A	A	A	X
Heptan	B	C	A	B	A	B	D	A	X	A	B/70	A	A	A	A	A	A
Hexan	B	C	A	A	D	B	D	A	X	A	B/70	A	A	A	A	A	A
Hexanol	A	C	A	D	D	D	A	A	X	X	A/70	A/70	X	A	A	A	A
Hexylalkohol	B	B	A	D	B	D	A	B	A	X	X	X	A	A	A	A	X
Hexylenglykol	X	X	A	D	A	X	C/70	A	X	X	X	X	X	A	A	A	A
Hilo MS #1	D	X	X	D	D	B	A	D	X	X	X	X	X	X	X	X	X
Hochofengas	X	A	A	B	D	D	D	A	A	X	X	D	X	X	X	X	X
Holz Alkohol	X	X	A	X	A	D	A	D	A	X	X	X	X	X	X	X	X
Holzöl	X	X	A	A	D	C/70	D	A	A	X	X	X	X	A	A	A	X
Houghto-Safe 271																	
(Wasser und Glykolbasis)	X	A	A	B	B	D	A	B	X	X	X	X	X	X	X	X	X
1010, Phosphatester	D	A	A	B	D	A	A	A	X	X	X	X	X	X	X	X	X
1055, Phosphatester	D	A	A	B	D	A	A	A	X	X	X	X	X	X	X	X	X
1120, Phosphat	D	A	A	B	D	A	A	A	X	X	X	X	X	X	X	X	X
5040 (Wasser / Öl-Emulsion)	A	D	A	B	B	D	D	A	X	X	X	X	X	X	X	X	X
620 Wasser / Glykol	B	A	A	A	B	B	A	B	X	X	X	X	X	X	X	X	X
Hydrauliköle (Petroleum)	A	D	A	A	B	X	D	A	A	A	D	B	X	A	A	A	A
Hydrauliköle (synthetisch)	A	D	A	A	D	B	D	A	A	X	D	B	X	A	A	A	A
Hydrazin (Diamin)	D	A	A	D	B	D	A	D	X	X	C	B	A/120	A	D	A	A
Hydrochinon	C	A	A	X	D	X	D	C	A	X	A	A	A	A	B	B	B
Hydrofluorkieselsäure	D	B	A	B	B	D	A	A	A	X	A	X	A	D	D	D	B
Hydrolube-Wasser / Ethylenglykol	A	A/250	A	B/150	B/70	D	A/70	A/70	X	X	A	D	A	A	A	A	A
Hydroxyessigsäure	D	A	A	X	D	D	A/70/100%	D	X	X	X	C	X	D	B	B	X
Hydyn	B	D	A	X	B	X	A	D	X	X	X	X	X	X	X	X	X

LEITFADEN

A = Ausgezeichnet, B = Gut, C = Mittel bis Schlecht, D = Nicht empfohlen

X oder Klammern um einen Bewertungsbuchstaben bedeuten, dass keine Daten verfügbar sind.

Die Bewertungen basieren auf Belastungstests in ähnlichen chemischen Gruppen.

* Alle Angaben in Grad Celsius



MATERIAL	NITRIL	SANTOPRENE®	PTFE	HYTREL®	NEOPRENE®	URETHAN	EPR/EPDM	VITON®	UHMW-PE	LEDER	POLYPROPYLEN	ACETAL	PVDF	ALUMINIUM	GUSSEISEN	ROSTFREI	HASTELLOY®
Hypochlorige Säure	D	A	A	X	D	D	B	A	A	X	A	D	A	D	D	D	A
Hypoidfett (Parapoid 10-C)	B	X	A	X	D	D	D	C	X	X	X	A	X	X	X	X	X
Iodoform	B	B	A	X	B	D	B	A	X	X	X	X	A	B	A	B	D
Iodpentafluorid	D	B	A	X	D	D	D	D	D	X	X	X	X	X	X	X	X
Isoamylacetat	D	X	A	X	D	D	B	D	X	X	X	X	X	A	A	A	A
Isoamylalkohol	X	X	A	X	A	C	A	A	X	X	X	X	X	X	X	X	X
Isoamylbutyrat	D	X	A	X	X	X	X	D	X	X	X	X	X	A	A	A	A
Isoamylchlorid	D	X	A	X	D	X	D	A	X	X	X	X	X	D	X	X	X
Iso-Butan	X	X	A	X	D	A	D	A/70	X	X	X	X	X	X	X	X	X
Isobuttersäure	D	X	A	X	B	X	A	X	X	X	X	X	X	A	X	X	X
Iso-Butylacetat	D	X	A	X	D	X	C/70	D	X	X	X	X	X	A	A	A	A
Isobutylalkohol Isobutyl (2-Methyl-1-Propanol)	C	A	A	B	A	D	B	A	X	X	A/70	A	A	B	C	A	A
Isobutylalkohol	B	A	A	X	A/80	D	A/160	A/75	A	X	A/70	A	A	B	C	A	A
Isobutylamin	D	X	A	X	X	X	X	D	X	X	X	X	X	X	X	X	X
Isobutylchlorid	D	X	A	X	X	X	X	B	X	X	X	X	X	D	B	B	A
Iso-Butyl-N-Butan	D	X	A	D	X	D	X	B	X	X	X	X	X	X	X	X	X
Isocyanate	C	X	A	B	X	B	X	B	X	X	A	A	X	X	A	A	A
Isododecan	A	X	A	X	B/70	B/70	D	A/70	X	X	X	X	X	B	B	B	B
Isooctan	C	C	A	A/158	B	A	A/70	A	A	X	A/120	X	A/70	A	A/70	A/70	A
Isopentan	A	X	A	X	D	B	D	A	X	X	X	X	X	X	X	X	X
Isophoron (Keton)	D	B	A	X	D	D	A	D	X	X	X	X	X	A	A	A	A
Isopropanol (Isopropylalkohol)	A	B	A	A/70	B/120	B	A/160	A/170	X	A	A	A	A	A	A	A	A
Isopropylacetat	D	B	A	C	D	D	B	D	C	X	A	A	X	B	A	A	B
Isopropylalkohol (Isopropanol)	A	B	A	A	B	D	A	A	A	A	A	A	A	A	A	A	A
Isopropylamin	D	X	A	X	X	X	X	D	X	X	X	X	X	X	A	A	X
Isopropylbenzol (Cumol)	D	X	A	X	D	D	D	A	D	X	X	X	X	X	X	X	X
Isopropylchlorid	D	C	A	X	D	D	D	A	X	X	D	A	X	D	A	A	X
Isopropylether	B	C	A	X	D	B	D	D	A	X	B/70	A	X	A	X	A	A
Jod	B	A	A	B	D	D	B	A	B	X	A	A	A/150	D	D	D	B
JP-1	C	D	A	X	D	C	D	A	A	X	D	A	A	A	A	A	A
JP-2	C	C	A	X	D	C	D	A	A	X	D	A	A	A	A	A	A
JP-3 (Mil-J-5624)	C	C	A	X	D	C	D	A	A	X	A/70	A	A	A	A	A	A
JP-4 (Mil-J-5624)	A	D	A	A	D	C	D	A	A	X	A/70	A	A	A	A	A	A
JP-5 (Mil-J-5624)	C	C	A	X	D	B	D	A	A	X	A/70	A	A	A	A	A	A
JP-6 (Mil-J-25656)	C	C	A	X	D	C	D	A	A	X	D	A	A	A	A	A	A
JP-X(Mil-F-25604)	A	C	A	X	B	X	D	D	A	X	D	A	A	A	A	A	A
Kaffee	A	A	A	X	A	D	A	A	A	X	A	A	X	A	X	A	A
Kal. Hydroxid (Ätzkali)(Lye)	A	A	A	A	B	B	A	B	A	X	A	A	A/150	D	C	A	B
Kalium Cupro Cyanid	X	A	A	X	A	X	B	A	X	X	A	C	A	X	X	X	X
Kaliumacetat	B	A	A	X	B	D	A	D	A	X	A	A	A	D	A	B	B
Kaliumbicarbonat	A	A	A	X	A	D	A	A	A	A	A	A	A	C	A	B	B
Kaliumbisulfit	A	X	A	X	A	A	A	A	X	X	A	X	X	X	X	X	X
Kaliumbromid	A	A	A	X	A	D	A	A	A	A	A	A	A	C	D	A	A
Kaliumcarbonat (Pottasche)	A	A	A	D	A	D	A	A	A	X	A	A	A	C	B	A	B

LEITFADEN

A = Ausgezeichnet, B = Gut, C = Mittel bis Schlecht, D = Nicht empfohlen

X oder Klammern um einen Bewertungsbuchstaben bedeuten, dass keine Daten verfügbar sind.

Die Bewertungen basieren auf Belastungstests in ähnlichen chemischen Gruppen.

* Alle Angaben in Grad Celsius



MATERIAL	NITRIL	SANTOPRENE®	PTFE	HYTREL®	NEOPRENE®	URETHAN	EPR/EPDM	VITON®	UHMW-PE	LEDER	POLYPROPYLEN	ACETAL	PVDF	ALUMINIUM	GUSSEISEN	ROSTFREI	HASTELLOY®
Kaliumchlorat	A	A	A	X	A	A	A	A	A	A	A	A	A	B	C	A	B
Kaliumchlorid	A	A	A	D	A	A	A	A	A	A	A	A	A	B	B	C	B
Kaliumchromat	A	A	A	X	A	B	A	A	A	A	A	D	A	A	A	B	A
Kaliumcyanid	A	A	A	B	A	A	A	A	A	A	A	C	A	D	B	A	B
Kaliumdichromat	A	A	A	B	A	B	A	A	A	X	A	D	A	A	B	A	B
Kaliumferricyanid	X	X	A	X	A	X	A	A	A	X	A	B	A	B	C	B	B
Kaliumhypochlorit	B/70	X	B	X	B	B	A	D	X	X	D	D	A	D	D	D	B
Kaliumiodid	B	X	A	X	A	X	A	A	B	X	A	X	A	B	X	B	B
Kaliumnitrat	A	A	A	X	A	A	A	A	A	A	A	B	A	A	B	B	B
Kaliumpermanganat	D	A	A	D	A	B	A	A	A	X	B	C	A	B	B	B	A
Kaliumphosphat	X	X	A	X	A	C	A	A	X	X	X	X	X	D	D	B	B
Kaliumsalze	A	X	A	X	A	A	A	A	X	X	X	X	X	X	X	X	X
Kaliumsulfat	A	A	A	B	A	A	A	A	A	X	A	B	A	B	B	A	A
Kaliumsulfid	A	X	A	X	A	A	A	A	A	X	A	X	A	D	B	B	B
Kaliumsulfit	A	X	A	X	A	A	A	A	A	X	A	X	A	A	D	B	X
Kaliumtriphosphat	A	X	D (A)	X	A	B	X	A	A	X	X	X	X	X	X	X	X
Kalk Schwefel	A	B	A	X	A	A	A	A	A	X	A	X	A	D	X	A	X
Kalziumhydroxid - 10 % (Kochen)	A	A	A	B	A	A	A	A	D	A	A	A/150	A	C	A	A	A
Kalziumsäuresulfat	X	X	A	X	C	X	B	D	X	X	X	X	X	X	X	X	X
Kalziumsulfid	A	A	A	X	B	A	A	A	X	X	A/120	X	A	A	B	B	A
Kalziumsulfit	B	A	A	X	A	A	A	A	X	X	X	X	X	B	B	A	X
Kasein	X	A	A	X	A	X	A	A	X	X	X	X	X	B	X	B	B
Kel F Flüssigkeiten	X	X	A	X	X	X	A	B	X	X	X	X	X	X	X	X	X
Kerosin	A	C	A	A	X	B	X	A	C	A	B/72	A	A	A	A	A	B
Ketone	D	C	A	D	D	D	A	D	C	A	D	A	A/70	B	X	A	A
Keystone # 87HX-Fett	X	X	A	X	D	A	D	A	A	X	X	X	X	X	X	X	X
Kieferöl	B	C	A	D	D	D	D	A	C	A	X	X	X	A	B	A	X
Kleben	D	A	A	A	A	A	A	A	A	X	A	B	A	B	A	A	A
Kobaltchlorid	A	A	A	X	A	D	C	A	X	X	A	X	X	D	D	X	X
Kohlendioxid	B	A	A	C	A	C	A	B	C	A	A	A	A	A	D	A	A
Kohlengas	X	X	A	B	A	B	A	A	X	X	X	X	X	X	X	X	X
Kohlenmonoxid	A	A	A	A	B	A	C	A	C	X	A	B	A	A	A	A	A
Kohlensäure	B	A	A	C	A	C	A	A	B	A	A	A	A	D	B	A	X
Kohlensäurehaltige Getränke	A	A	A	X	A	B	A	A	X	X	A	X	A	C	D	A	A
Kohlenstoffbisulfid	D	D	A	B	D	C	D	A	D	X	D	B	A	A	B	B	B
Kohlenstoffdisulfid	D	D	A	C	D	C	D	A	D	X	D	B	A/70	A	B	B	B
Kohle-Teere	D	D	A	D	C	D	D	A	X	X	C	D	X	X	X	X	A
Kokosnussöl (Kokosnuss-Butter)	B	B	A	X	C/140	C	B	A	A	X	X	X	X	B	A	A	X
Koks-Ofen-Gas	D	B	A	X	C	D	D	A	A	X	X	X	A	X	X	X	X
Kolophonium Papiermühle	X	A	A	X	A	D	A	A	D	X	A	B	X	A	D	A	A
Königswasser(20 % Stickstoff, 80 % HCl)	D	D	A	D	D	D	B/140	A/70	B	X	B/70	D	A/70	D	D	D	C
Kreosole	D	C	A	X	D	D	D	A	D	X	D	B	A/150	B	C	A	B
Kupferacetat	X	A	A	D	B	D	A	D	X	X	X	A	A	D	D	C	B
Kupferchlorid - 1 %	A	A	A	A	A	D	A	A	A	X	A	A	A	D	D	D	B

LEITFADEN

A = Ausgezeichnet, B = Gut, C = Mittel bis Schlecht, D = Nicht empfohlen

X oder Klammern um einen Bewertungsbuchstaben bedeuten, dass keine Daten verfügbar sind.

Die Bewertungen basieren auf Belastungstests in ähnlichen chemischen Gruppen.

* Alle Angaben in Grad Celsius



MATERIAL	NITRIL	SANTOPRENE®	PTFE	HYTREL®	NEOPRENE®	URETHAN	EPR/EPDM	VITON®	UHMW-PE	LEDER	POLYPROPYLEN	ACETAL	PVDF	ALUMINIUM	GUSSEISEN	ROSTFREI	HASTELLOY®
Kupfercyanid	A	A	A	A	A	A	A	A	A	X	A	A	A	D	D	A	A
Kupferfluorborat	X	A	A	A	A	A	X	A	X	X	X	B	X	D	D	D	B
Kupfernitrat	B	A	A	A	A/140	B/70	A	A	A	A	A	A	A	D	D	A	A
Kupfersulfat - 5 % Lösung	A	A	A	A	A	A	A	A	A	X	A	D	A	D	D	A	A
Lachgas	A	X	A	X	B	B	A	A	X	X	A	X	D	B	B	D	B
Lack	B/70°	D	A	X	D	B	D	A	A	A	A	X	A	A	X	A	A
Lacke	D	C	A	D	D	D	D	D	A	X	C	A	D	A	C	A	A
Lack-Lösungsmittel	D	C	A	B	D	D	D	D	A	B	C	A	D	A	B	A	X
Lactam-Aminosäuren	X	X	A	X	B	X	B	D	X	X	X	X	X	X	X	X	X
Lactol	X	X	A	X	D	X	X	A	X	X	D	A	X	A	A	A	A
Latex	A	A	A	X	A	D	A	A	X	X	A	A	X	A	X	A	X
Laugen-Lösungen	B	A	A	C	A	B	A	B	A	X	A	D	A/150	X	X	A	X
Laurylalkohol (N-Dodecanol)	X	X	A	X	X	D	X	B	A	X	X	X	X	A	A	A	A
Lavendel Öl	B	B	A	X	D	X	D	A	X	X	X	X	X	X	X	X	X
Lebertran (Fischöl)	X	C	A	X	B/70	A	A	A	A	X	X	X	X	A	D	A	X
Lehigh X1169	X	X	A	X	B	A	D	A	X	X	X	X	X	X	X	X	X
Lehigh X1170	X	X	A	X	B	A	D	A	X	X	X	X	X	X	X	X	X
Leichtes Fett	X	X	A	X	D	A	D	A	X	X	X	A	X	X	X	X	X
Leinsamenöl	A	B	A	B	A	B	C	A	X	X	A	A	A	A	A	A	A
Lignin-Likör	X	X	A	X	A	D	D	A	X	X	X	X	X	X	X	A	X
Ligroin (Petrolether oder Benzol)	B	B	A	X	B	C	D	A	X	X	B/175	B	A	X	A	A	X
Limette Slurries	A	A	A	X	A	B	C	D	X	X	X	X	X	B	X	B	X
Limette	A	A	A	A	A	B	A	A	X	X	B	X	A	C	A	A	X
Limonen	D	X	A	X	D	X	D	A	X	X	X	X	X	X	X	X	X
Lindenbleiche	B	A	A	X	B	X	A	A	X	X	B	X	X	D	X	A	X
Linolsäure	B	B	A	X	D	X	D	B	A	X	A	X	A	A	X	A	A
Liquimoly	A	X	A	X	B	B/70	D	A	X	X	X	X	X	X	X	X	X
Lithiumbromid	A	X	A	X	D	D	A	A	X	X	X	X	A	X	A	X	X
Lithiumchlorid	A	X	A	X	A	D	A	A	D	X	A/125	A	X	D	B	A	A
Lithiumhydroxid	D	X	A	X	D	D	A	C	D	X	A/70	X	X	D	B	B	B
Lysol	B	X	A	X	B	X	X	X	X	X	X	X	X	X	X	X	X
Magnesium Sulfat	B	A	A	X	A	X	A	A	X	X	X	X	X	X	X	X	X
Magnesiumbisulfat	C	X	A	X	B	X	X	X	X	X	X	X	X	X	X	X	X
Magnesiumcarbonat	A	A	A	X	A	B	B	A	A	X	A	A	A	D	B	A	B
Magnesiumchlorid	A	A	A	B	A	X	A	A	A	A	A	B	A	D	D	D	A
Magnesiumhydroxid Hydroxid (Milch von Magnesia)	A	A	A	B	A	A	A	A	A	A	A	A	A	D	B	A	A
Magnesiumnitrat	A	A	A	X	A	B	A	A	A	X	A	A	A	D	D	A	A
Magnesiumoxid	A	A	A	X	A	X	A	A	X	X	X	A	X	B	A	A	A
Magnesiumsalze	A	A	A	X	A	A	A	A	X	X	X	X	X	X	X	X	X
Magnesiumsulfat	B	A	A	B	A	D	A	A	B	A	B	A	A	D	C	A	B
Maische	A	A	X	X	A	A	X	X	X	X	X	A	X	X	X	A	X
Maisöl	B	D	A	A	C	A	D	A	A	A	A	X	A	B	C	B	X
Malathion	X	X	A	D	X	D	D	A	X	X	X	X	X	X	X	X	X
Maleinsäureanhydrid	D	A	A	X	D	X	D	A	X	X	X	A	X	A	B	A	A
Malz Getränke	B	A	A	X	A	B	A	A	A	X	X	X	X	X	X	X	X

LEITFADEN

A = Ausgezeichnet, B = Gut, C = Mittel bis Schlecht, D = Nicht empfohlen

X oder Klammern um einen Bewertungsbuchstaben bedeuten, dass keine Daten verfügbar sind.

Die Bewertungen basieren auf Belastungstests in ähnlichen chemischen Gruppen.

* Alle Angaben in Grad Celsius



MATERIAL	NITRIL	SANTOPRENE®	PTFE	HYTREL®	NEOPRENE®	URETHAN	EPR/EPDM	VITON®	UHMW-PE	LEDER	POLYPROPYLEN	ACETAL	PVDF	ALUMINIUM	GUSSEISEN	ROSTFREI	HASTELLOY®
Mandelöl (künstlich)	D	C	A	D	D	D	B/70	D	X	X	D	X	X	X	X	X	X
Manganchlorid	A	X	A	X	B	B	C	A	A	X	A	X	X	X	D	X	B
Mayonnaise	A	A	A	X	A	D	D	A	A	A	A	A	A	D	D	A	A
MCS 312	D	X	A	X	D	X	D	A	X	X	X	X	X	X	X	X	X
MCS 352	D	X	A	X	D	D	A	D	X	X	X	X	X	X	X	X	X
MCS 463	D	X	A	X	D	D	A	D	X	X	X	X	X	X	X	X	X
Meerwasser	A	A	A	A	A	A	A	A	A	A	A	A	A	D	D	C	A
Melaminharze	C	B	A	X	D	D	A	A	X	X	X	A	X	X	X	D	A
Melasse	A	A	A	B	A	B	A	A	A	A	A	B	A	A	A	A	X
Mercaptan	D	X	A	X	D	D	A	D	X	X	X	X	X	X	X	X	X
Mesityloxid	D	C	A	X	D	D	B	D	X	X	X	X	X	A	A	A	A
Methan	B	C	A	B	B	C	D	A	X	X	B	A	A	A	X	A	A
Methanol	A	A	A	A	A	D	A	D	A	X	A/120	A	A	B	X	A	A
Methyl Anilin	D	X	A	X	B	D	D	B	X	X	X	X	X	X	X	X	X
Methylacetat	D	B	A	C	D	D	B	D	X	X	C	A	B	A	A	A	A
Methylacetoacetat	D	X	A	X	D	D	B	D	X	X	X	X	X	X	A	A	A
Methylacetone	D	B	A	X	D	X	A	D	X	X	D	A	D	A	A	A	A
Methylacrylat	D	D	A	X	D	D	B	D	X	X	X	A	B	X	A	A	X
Methyl-Acrylsäure	X	A	A	X	C	D	B	C	X	X	X	A	X	X	X	X	X
Methylalkohol	A	A	A	A	C	D	A	C	A	A	A	A	A	B	A	B	A
Methylamin	B	X	A	X	C	X	A	C	X	X	X	A	C	B	A	A	B
Methylamin	X	A	A	X	X	X	A	X	X	X	X	A	C	B	A	A	B
Methylamylalkohol	B	X	A	X	D	X	X	D	X	X	X	X	X	A	A	A	A
Methylbenzoat	D	X	A	X	A	D	D	A	X	X	X	X	X	X	X	X	X
Methylbromid	B	D	A	X	A	D	D	A	C	X	D	A	A	D	A	A	B
Methylbutylketon	D	C	A	X	D	D	A	D	X	X	D	A	D	A	X	A	X
Methylbutyrat	D	X	A	X	D	X	D	X	X	X	X	X	X	A	A	A	A
Methylcarbonat	D	X	A	X	D	D	D	A	X	X	X	X	X	X	X	X	X
Methylcellosolve	C	B	A	X	B	D	B	D	X	X	B	A	A	A	C	X	X
Methylcellulose	B	X	A	X	B	B/70	B	D	X	X	X	X	X	X	X	X	X
Methylchlorformiat	D	X	A	X	D	D	D	A	X	X	X	X	X	X	X	X	X
Methylchlorid	D	D	A	D	D	D	D	B	C	X	D	A	A	D	D	A	B
Methylcyanid	C	X	A	X	A	X	A	D	X	X	X	X	X	X	X	X	X
Methylcyclopentan	D	C	A	X	D	D	X	A	A	X	X	A	X	X	X	X	X
Methyl-D-Bromid	D	X	A	X	D	D	X	A	X	X	X	X	X	X	X	X	X
Methyldichlorid	D	D	A	X	D	X	D	A	X	X	D	A	D	D	X	X	X
Methylenbromid	D	X	A	X	D	X	D	C	X	X	X	X	A	D	A	A	A
Methylenchlorid	C	D	A	D	D	D	C	B	D	X	D	A	B	D	B	A	A
Methylen-dichlorid	D	X	A	X	D	D	D	B	X	X	X	X	X	X	X	X	X
Methylether	X	X	A	X	C	X	A	A	X	X	X	X	X	X	X	X	X
Methylethylketon (MEK)	B	B	A	B	D	D	A	D	D	X	C/125	B	D	A	A	A	A
Methylformiat	D	B	A	X	B	D	B	D	X	X	X	A	X	A	B	B	X
Methylhexan	X	X	A	X	B	X	D	A	X	X	X	X	X	X	X	X	X
Methyliodid	D	X	A	X	D	X	A	X	X	X	X	X	X	D	A	A	A
Methylisopropylketon	D	C	A	X	D	D	C	D	C	X	C	A	X	A	C	A	X

LEITFADEN

A = Ausgezeichnet, B = Gut, C = Mittel bis Schlecht, D = Nicht empfohlen

X oder Klammern um einen Bewertungsbuchstaben bedeuten, dass keine Daten verfügbar sind.

Die Bewertungen basieren auf Belastungstests in ähnlichen chemischen Gruppen.

* Alle Angaben in Grad Celsius



MATERIAL	NITRIL	SANTOPRENE®	PTFE	HYTREL®	NEOPRENE®	URETHAN	EPR/EPDM	VITON®	UHMW-PE	LEDER	POLYPROPYLEN	ACETAL	PVDF	ALUMINIUM	GUSSEISEN	ROSTFREI	HASTELLOY®
Methylmethacrylat	D	B	A	X	D	D	D	D	X	X	A	A	B	B	C	A	X
Methyloleat	D	C	A	X	D	X	B	A	X	X	X	A	X	X	X	X	X
Methylsalicylat	D	B	A	X	D	X	B	B	X	X	B	A	B	A	A	X	X
Milch	A	A	A	B	A	D	A	A	A	A	A	A	A	A	D	A	A
Milchsäure - 5 % Lösung	B	A	A	D	A	B	A	A	A	X	A	A	A/70	C	D	A	B
Mineralöl (raffiniert)	B	C	A	A	B	B	D	A	A	X	B	A	A	X	X	X	X
Mineralöl	A	D	A	A	A	A	D	A	C	A	B	A	A	A	A	A	A
MLO-7277 Hydr.	X	X	A	X	D	D	D	A	X	X	X	X	X	X	X	X	X
MLO-7557	X	X	A	X	D	D	D	A	X	X	X	X	X	X	X	X	X
MLO-8200 Hydr.	X	X	A	X	A	A	D	A	X	X	X	X	X	X	X	X	X
MLO-8515	X	X	A	X	B	D	D	A	X	X	X	X	X	X	X	X	X
Molke	A	A	X	X	X	X	X	A	X	X	X	X	X	B	X	A	X
Monochlorbenzol	D	D	A	C	D	D	D	A	B	X	D	A	A/150	D	A	A	X
Monochlordifluormethan	D	D	A	D	A	D	A	D	X	X	A	X	A	A	A	A	X
Monochloressigsäure	D	D	A	D	A	D	C	B	D	X	A	B	A	D	D	D	B
Monoethanolamin	D	A	A	D	B	D	B	D	X	X	D	D	D	B	A	A	X
Monomethylanilin	D	B	A	D	D	D	D	B	A	X	X	X	X	X	X	X	X
Monomethylether	A	C	A	D	B	X	A	A	X	X	X	X	X	X	X	X	X
Monomethylhydrazin	B	X	A	D	B	X	A	X	A	X	X	X	X	X	X	X	X
Mononitrotoluol und Dicitrotoluol (40/60 Mischung)	A	X	A	D	D	D	D	C	X	X	X	X	X	X	X	X	X
Muriatic Säure (10-20 % HCL)	B	A	A	D	D	B	A	A	A	X	A	D	A	D	D	D	A
Napalm	B	X	X	D	X	B	D	A	X	X	X	X	X	X	X	X	X
Naphthalin (Teer-Kampfer)	D	C	A	B	D	B	D	A	B	X	B	A	A	B	A	A	A
Naphthensäure	B	B	A	D	D	X	D	A	X	X	X	A	X	B	B	A	B
Naptha	A	C	A	A	D	C	D	A	C	A	C	A	A	A	B	A	A
Naptha-Kohlenteer (Benzol)	D	C	A	D	D	B	D	A	X	X	C	A	A	A	A	A	A
Natrium Chlorat	A	A	A	X	A	A	A	A	A	X	A	A	A	B	B	A	A
Natriumaluminat	A	A	A	X	A	X	A	A	X	X	A	A	A	C	A	A	A
Natriumaluminiumsulfat	A	A	A	X	A	A	A	A	X	X	X	X	X	X	X	X	B
Natriumbicarbonat	A	A	A	B	A	A	A	A	A	X	A	A	A	A	C	A	B
Natriumbisulfat	A	A	A	AC	A	A	A	A	A	X	A	A	A	D	D	A	B
Natriumbisulfid	A	A	A	B	A	A	A	A	A	X	A	A	A	A	D	A	A
Natriumborat (Borax)	A	A	A	B	A	A	A	A	A	X	A/140	A	A	C	B	B	A
Natriumbromid	X	A	A	X	A	X	A	A	A	X	A	X	A	C	C	B	B
Natriumcarbonat	A	A	A	B	A	A	A	A	A	X	A	A	A	C	B	A	A
Natriumchlorid	A	A	A	A	A	A	A	A	A	X	A	A	A	C	B	C	A
Natriumchromat	A	A	A	X	A	X	X	A	X	X	A	D	A	A	A	A	A
Natriumcitrat	D	A	X	X	X	X	X	X	A	X	X	X	X	X	X	B	B
Natriumcyanid	A	A	A	B	A	A	A	A	A	X	A	B	A	D	B	A	A
Natriumdichromat	A	A	A	B	B	B	A	B	A	X	A	X	A	X	X	X	X
Natriumdichromat	B	A	A	X	A	A	A	A	A	X	A	D	A	C	C	B	C
Natriumferricyanid	A	A	A	X	A	X	A	A	A	X	A	X	A	A	D	B	B
Natriumfluorid	A	A	A	X	A	B	A	A	A	X	A	X	A	B	X	B	B
Natriumhydrogensulfat	X	X	X	X	X	X	X	X	X	X	X	X	X	X	X	X	X

LEITFADEN

A = Ausgezeichnet, B = Gut, C = Mittel bis Schlecht, D = Nicht empfohlen

X oder Klammern um einen Bewertungsbuchstaben bedeuten, dass keine Daten verfügbar sind.

Die Bewertungen basieren auf Belastungstests in ähnlichen chemischen Gruppen.

* Alle Angaben in Grad Celsius



MATERIAL	NITRIL	SANTOPRENE®	PTFE	HYTREL®	NEOPRENE®	URETHAN	EPR/EPDM	VITON®	UHMW-PE	LEDER	POLYPROPYLEN	ACETAL	PVDF	ALUMINIUM	GUSSEISEN	ROSTFREI	HASTELLOY®
Natriumhydroxid										X							
20 % (kalt)	B	A	A	A	B	B	A	A	A	X	A	A	A	D	B	A	B
50 % Lösung (kalt)	D	A	A	B	C	B	A	A	A	X	A	A	C	D	C	B	A
80 % Lösung (kalt)	D	X	A	D	C	B	A	A	A	X	A	A	C	D	C	D	B
Natriumhypochlorit 0-20 %	D	B	A	C	B	D	B	C	A	X	B	D	A	D	D	C	A
Natriummetasilikat	A	A	A	X	A	B/70	A	A	X	X	A	B	A	B	X	A	A
Natriumnitrat	C	A	A	B	B	B/70	A	A	A	X	A	A	A	A	A	A	A
Natriumperborat	B	A	A	B	B	B/70	A	A	A	X	A	B	A	D	B	A	B
Natriumperoxid (Natriumdioxid)	B	B	A	B	B	D	A	A	A	X	B	F	A	B	A	B	B
Natriumphosphat (Mono)	A	A	A	B	C	A	A	A	X	X	A	A	A	D	D	A	X
Natriumphosphat (Tribasic)	B	A	A	B	C	A	A	A	A	X	A	A	A	D	D	A	A
Natriumphosphat (zweibasisch)	B	A	A	B	B	A	A	A	X	X	A	A	A	D	D	A	X
Natriumphosphat	A	A	A	C	A	A	A	A	A	X	A	A	A	D	B	B	A
Natriumsäuresulfat	A	A	A	X	A	A	A	A	A	X	A	X	X	X	B	X	X
Natriumsilikat (Wasserglas)	A	A	A	B	A	B	A	A	A	X	A	C	A	C	B	A	B
Natriumsulfat (Salzkuchen)	A	A	A	B	A	A	A	A	A	X	A	B	A	B	A	A	B
Natriumsulfid - Gesättigt	A	A	A	B	A	A	B	B	A	X	A	A	A	D	B	B	A
Natriumsulfid	A	A	A	B	A	A	A	A	A	X	A	B	A	D	A	A	B
Natriumsulfit	A	A	A	B	A	A	A	A	A	X	A	A	A	A	D	A	B
Natriumtetraborat	B	A	A	B	A	B	A	A	A	X	A	A	A	A	B	A	B
Natriumtetraphosphat	X	A	X	X	X	X	X	X	X	X	X	X	X	X	X	X	X
Natriumthiosulfat (Antichlor)	A	A	A	X	X	X	X	X	X	X	A	B	A	A	C	A	B
Natriumtriphosphat	X	X	A	B	A	A	A	A	X	X	A	C	A	B	C	A	A
Neatsfoot-Öl	A	B	A	D	D	A	B	A	X	X	X	B	X	A	A	A	X
Nelkenöl	X	C	A	X	X	X	X	X	X	X	X	X	X	X	D	A	X
Neohexan	A	X	A	D	X	X	X	A	X	X	X	X	X	X	X	X	X
Neosol	A	X	A	D	A	X	X	C	X	X	X	X	X	B	B	A	A
Neville Säure	D	A	A	D	D	X	B	A	X	X	X	X	X	X	X	X	X
N-Hexaldehyd	D	C	A	D	A	B	A	D	X	X	X	X	X	A	A	A	X
Nickelacetat	B	A	A	X	B	D	A	D	X	X	A	X	A	B	X	A	X
Nickel-Ammonium-Sulfat	C	A	A	X	A	X	X	A	X	X	X	X	X	X	X	X	X
Nickelchlorid	A	A	A	D	B	A	A	A	A	A	A	B	A	D	D	B	A
Nickelnitrat	A	A	A	X	A	A	A	A	A	X	A	D	A	D	X	A	B
Nickelsalze	A	A	A	X	B	A	A	A	X	X	X	X	X	X	X	X	X
Nickelsulfat	A	A	A	D	A	A	A	A	A	A	A	A	A	D	D	A	B
Nikotin	A	X	A	B	C	A	X	A	X	X	X	X	X	X	X	X	X
Nikotinsäure	A	X	A	X	A	X	A	X	X	X	X	X	X	X	X	X	X
Niter Kuchen	A	A	A	X	A	A	A	A	A	X	X	X	X	X	X	X	X
Nitran (Ammoniakdünger)	B	X	A	X	B	X	X	C	X	X	X	X	X	X	X	X	X
Nitrobenzol	D	B	A	D	D	D	C	A	D	X	B/70	B	A/70	C	C	B	B
Nitroethan	D	A	A	X	C	D	B	D	A	X	C	B	X	A	A	A	A
Nitroglycerin	X	A	A	D	A	A	A	A	X	X	X	X	X	X	X	X	X
Nitromethan	D	A	A	D	C	D	B	D	A	X	C	X	A/120	A	A	A	A
Nitropropan	X	B	A	X	D	D	B	D	A	X	X	X	X	A	A	A	A
N-Octan	D	B	A	X	D	D	D	A	X	X	D	X	A	X	X	X	X

LEITFADEN

A = Ausgezeichnet, B = Gut, C = Mittel bis Schlecht, D = Nicht empfohlen

X oder Klammern um einen Bewertungsbuchstaben bedeuten, dass keine Daten verfügbar sind.

Die Bewertungen basieren auf Belastungstests in ähnlichen chemischen Gruppen.

* Alle Angaben in Grad Celsius



MATERIAL	NITRIL	SANTOPRENE®	PTFE	HYTREL®	NEOPRENE®	URETHAN	EPR/EPDM	VITON®	UHMW-PE	LEDER	POLYPROPYLEN	ACETAL	PVDF	ALUMINIUM	GUSSEISEN	ROSTFREI	HASTELLOY®
Octachloro Toluol	D	X	A	X	D	D	D	A	X	X	D	X	X	D	X	X	X
Octadecan	X	B	A	X	B	A	D	A	X	X	X	X	X	X	X	X	X
Octylacetat	D	X	A	X	X	X	X	D	X	X	X	X	X	A	X	A	X
Octylalkohol	B	X	A	X	B	D	B	B	X	X	X	X	X	X	X	X	X
Olein (Triolein)	X	D	A	X	C	X	X	X	X	X	X	X	X	X	X	X	X
Oleum (rauchende Schwefelsäure)	D	D	A	D	D	D	D	B	D	X	D	D	D	D	D	A	D
Oleumspiritus	D	D	A	B	D	C	D	A	A	X	D	X	D	D	D	B	X
Olivenöl	D	B	A	X	B	A	B	A	A	X	A	A	B	A	A	B	A
Ölsäure (rotes Öl)	D	B	A	A	C	B/70	C	A	A	A	A	A	A	A	B	A	A
Oronit 8200	X	X	A	B	A	A	D	A	X	X	X	X	X	X	X	X	X
Oronit 9515	X	X	A	X	X	X	X	X	X	X	X	X	X	X	X	X	X
Orthochlorethylbenzol	X	X	A	X	D	D	D	A	X	X	X	X	X	X	X	X	X
Ortho-Dichlorbenzol	X	D	A	D	D	D	D	A	X	X	X	X	X	X	X	X	X
OS 45 Typ 111 (OS45)	X	X	A	C	A	D	D	B	X	X	X	X	X	X	X	X	X
OS 45 Typ IV (OS45-1)	X	X	A	X	A	D	D	B	X	X	X	X	X	X	X	X	X
OS 70	X	X	A	X	A	D	D	A	X	X	X	X	X	X	X	X	X
Oxalsäure - 5 % (heiß und kalt)	C	A	A	D	B	A	A	A	A	X	A	D	A/120	B	D	B	B
Ozon	X	A	A	C	C	A	A	A	B	X	D	D	A	B	X	X	X
Palmitinsäure	A	B	A	A	B	A	B	A	X	A	A	A	A	C	C	A	B
Palmöl	X	B	A	X	D	A	D	A	A	X	X	A	A	A	A	A	X
Para-Dichlorbenzol	X	X	A	X	D	D	D	A	X	X	X	X	X	X	X	X	X
Paraffin	A	A	A	X	B	A	D	A	A	A	A	A	A	A	X	A	B
Paraformaldehyd	X	X	A	X	B	X	A	C	X	X	X	X	X	A	A	A	A
Paraldehyd	X	X	A	X	D	X	A	D	X	X	X	X	X	A	A	A	A
P-Cymen	D	B	A	X	D	D	D	A	X	X	X	X	X	X	X	X	X
P-Dichlorbenzol	D	D	A	D	D	D	D	A	D	X	B	B	A/150	D	B	B	A
Pech	A	X	A	D	D	D	D	A	X	X	X	X	X	X	X	X	X
Pentachlorethan (Pentalin)	D	X	A	X	D	X	X	A	X	X	D	A	A	D	A	A	A
Pentachlorphenol (PCP)	X	X	A	X	D	D	D	A	X	X	X	X	X	A	A	A	A
Pentan	X	X	A	X	B	D	D	A	C	X	X	A	A	A	B	B	B
Perchloräthylen (Tetrachlorethylen)	D	D	A	D	D	D	D	B	B	X	D	A	A	D	B	A	B
Perchlorsäure	D	D	A	D	B	D	B	A	C	X	X	C	A/120	D	D	B	X
Permachlor (Entfettungsmittel)	X	X	A	X	X	X	D	C/70	X	X	X	X	X	X	X	X	X
Petrolatum	A	X	A	X	B	D	D	A	X	X	A	A	A	B	X	A	A
Petroleumäther	A	X	A	X	D	B	D	A	A	X	A	A	B	B	B	A	D
Petroleum-Öle (sauer)	C	C	A	B	B	B	D	A	A	X	B	A	A	B	B	A	A
Pfefferminz Öl	X	C	X	X	D	X	X	A	C	X	X	X	X	X	X	A	X
Pflanzenöl	A	A	A	X	B	A	A	A	D	A	A	A	A	A	B	A	A
Phenol	D	A	A	D	D	D	X	A	C	X	C	A	A/70	B	D	A	A
Phenolsulfonsäure	X	X	Q	X	X	X	X	D	X	X	X	X	AB/120	B	B	B	A
Phenyl Acetat	X	X	A	X	D	D	B/70	D	X	X	X	X	X	X	X	X	X
Phenylbenzol	X	C	A	X	D	D	D	A	X	X	X	X	X	X	X	X	X
Phenylhydrazin	X	B	A	X	D	X	D	A	X	X	X	X	D	A	D	X	X
Phoron (Diisopropylidenacetone)	X	B	A	X	D	D	B	D	A	X	X	X	X	X	X	X	X
Phosphatester	X	X	A	X	D	D	A	D	X	X	X	X	X	X	X	X	X

LEITFADEN

A = Ausgezeichnet, B = Gut, C = Mittel bis Schlecht, D = Nicht empfohlen

X oder Klammern um einen Bewertungsbuchstaben bedeuten, dass keine Daten verfügbar sind.

Die Bewertungen basieren auf Belastungstests in ähnlichen chemischen Gruppen.

* Alle Angaben in Grad Celsius



MATERIAL	NITRIL	SANTOPRENE®	PTFE	HYTREL®	NEOPRENE®	URETHAN	EPR/EPDM	VITON®	UHMW-PE	LEDER	POLYPROPYLEN	ACETAL	PVDF	ALUMINIUM	GUSSEISEN	ROSTFREI	HASTELLOY®
Phosphoroxchlorid	X	X	A	X	D	X	X	X	X	X	X	X	X	B	B	B	B
Phosphorsäure 20 %	X	A	A	X	A	C	A	A	A	X	A	D	A	D	D	A	A
Phosphortrichloridsäure	D	B	A	X	D	X	A	A	A	X	D	D	A	D	B	A	X
Phthalsäure	D	X	A	X	C	X	A	A	A	X	A	X	A	B	A	B	B
Phthalsäureanhydrid	X	X	A	X	A	X	A	A	X	X	X	X	X	X	X	X	X
Pikrinsäure	B	B	A	D	C	C	C	A	A	A	B/70	D	A/70	C	D	D	D
Pinen	B	C	A	D	D	D	D	A	A	X	X	X	X	X	X	X	X
Piperidin	X	B	A	D	D	D	D	D	B	X	X	X	X	X	X	X	X
Polyvinylacetat-Emulsion	B	A	A	X	B	X	A	D	X	X	B/70	A	A	X	B	X	X
PRL-Hochtemp. Hydr. Öl	B/70	X	A	X	B	B	D	A	A	X	X	X	X	X	X	X	X
Produzent Gas	X	X	A	X	B	A	D	A	D	X	X	A	X	X	X	X	X
Propan (LPG)	B	C	A	B	B	B	D	A	C	X	D	A	A	A	B	A	A
Propan (verflüssigt)	B	X	A	B	B	B	D	A	C	X	B/70	A	B/20	A	A	A	A
Propan Propionitril	X	X	A	X	B	D	D	A	A	X	X	X	X	X	X	X	X
Propionaldehyd (Propanol)	X	X	A	X	D	D	A	D	X	X	X	X	X	A	A	A	A
Propionsäure	X	A	A	X	D	D	A	D	X	X	X	X	X	A	A	A	A
Propylacetat	D	B	A	X	D	D	B	D	X	X	C	A	A/70	A	X	A	A
Propylalkohol	B	A	A	X	A	D	A	A	A	X	A	A	A	A	A	A	A
Propylen	X	B	A	X	D	D	D	A	A	X	A	A	A	A	A	A	A
Propylen-Dichlorid	X	X	A	X	D	D	D	A	D	X	X	X	X	D	A	A	B
Propylenglykol	A	A	A	X	C	B	A	A	B	X	A	D	A	A	B	A	B
Propylenoxid	D	A	A	X	D	D	B	D	A	X	A/70	A	D	B	B	A	X
Propylnitrat	X	B	A	X	D	D	B	D	X	X	C	A	D	B	B	A	X
Pryanol, Transformatoröl	X	X	A	X	D	B	D	A	C	X	X	X	X	X	X	X	X
P-tertiäres Butylcatechol	X	B	A	X	B	X	B/70	A	X	X	X	A	X	C	B	B	X
Pydraul	X	X	X	X	X	X	X	X	X	X	X	X	X	X	A	A	A
Pyridin	X	A	A	C	D	D	B	D	D	X	C	B	D	B	A	B	A
Pyrogallussäure	X	X	A	X	A	D	B	A	C	X	X	D	A	X	D	A	B
Pyroligneous Säure	D	X	A	X	D	D	B	D	D	X	A	D	A	B	D	A	X
Pyrolube	X	A	A	X	D	D	B	A	X	X	X	X	X	X	X	X	X
Pyrrrol	X	C	A	X	D	X	D	D	X	X	X	X	X	X	X	X	X
Quartäre Ammoniumsalze	X	X	A/70	X	A	X	X	A	X	X	X	X	X	X	X	X	X
Quecksilber	A	A	A	A	A	A	A	A	A	A	A	A	A	C	A	A	A
Quecksilberbichlorid	B	B	A	X	A	A/70	A	A	X	X	X	X	X	X	X	X	X
Quecksilberchlorid	A	A	A	B	A	A	A	A	A	X	A	B	A	D	D	D	B
Quecksilbercyanid	A	A	A	D	B	X	A	A	A	X	A	X	A	D	C	A	A
Quecksilbernitrat	B	X	A	X	B	X	A	A	A	X	A	X	A	D	B	B	B
Quench Öl	X	X	A/70	X	D	A	D	A	X	X	X	X	X	A	X	A	A
Rapsöl	X	B	A	X	B	B/70	A	A	D	X	X	X	X	X	A	A	A
Rauchende Schwefelsäure Säure (20/50 % Oleum)	D	X	A	D	D	D	D	A	X	X	X	X	X	X	X	X	X
Reinigungsmittellösungen	B	B	A	B	B	A	A	A	A	X	A	A	A	A	A	A	X
Rindfleischextrakt	A	A	A	X	A	X	X	A	X	X	X	X	X	X	D	A	X
Rizinusöl	B	B	A	C	A	A	B	A	X	X	X	X	X	A	B	A	A
RJ-1 (Mil-F-25558)	X	X	X	X	B	B	D	A	A	X	X	X	X	X	X	X	X

LEITFADEN

A = Ausgezeichnet, B = Gut, C = Mittel bis Schlecht, D = Nicht empfohlen

X oder Klammern um einen Bewertungsbuchstaben bedeuten, dass keine Daten verfügbar sind.

Die Bewertungen basieren auf Belastungstests in ähnlichen chemischen Gruppen.

* Alle Angaben in Grad Celsius



MATERIAL	NITRIL	SANTOPRENE®	PTFE	HYTREL®	NEOPRENE®	URETHAN	EPR/EPDM	VITON®	UHMW-PE	LEDER	POLYPROPYLEN	ACETAL	PVDF	ALUMINIUM	GUSSEISEN	ROSTFREI	HASTELLOY®
Rohöl	C	C	A	B	B	D	D	A	B	X	B/150	D	A/120	A	A	A	B
Rohrsaft	B	A	A	X	A	D	A	A	X	X	B/72	A	B	B	A	A	X
Rosenöl	X	A	X	X	C	A	X	A	X	X	X	X	X	X	X	A	X
Rosinen	A	A	A	X	A	D	D	A	D	X	A	B	X	A	D	A	A
Rost-Inhibitoren	A	B	X	X	C	A	X	A	X	X	A	A	X	X	C	A	X
Rote Linie 100 Öl	X	X	X	X	B	A	D	A	X	X	X	X	X	X	X	X	X
Rotenon	X	X	A	X	A	X	A	A	X	X	X	X	X	X	X	X	X
RP-1 (Mil-R-25576)	X	X	X	X	C	C	D	A	A	X	X	X	X	X	X	X	X
Rum	A	A	A	X	A	D	A	A	X	X	A	A	X	X	X	A	A
Saccharoselösungen (Zucker)	A	A	A	B	A	A	A	A	A	X	X	A	X	A	B	A	A
Salatsoße	D	A	X	D	D	D	D	D	X	X	A	A	X	B	D	A	X
Salicylsäure	A	A	A	X	D	X	A	A	A	X	A	X	A	A	D	B	A
Salmiak	X	A	A	A	A	A	A	A	A	X	A	D	A	D	D	B	A
Salpetersäure																	
20 % Lösung	B	B	A	D	D	C	B	A	A	X	B/70	C	A	D	D	A	B
5 % bis 10 % Lösung	A	A	A	B	D	C	B	A	A	X	A/120	C	A/120	D	D	A	A
50 % Lösung (Kochen)	C	C	A	D	D	C	D	A	D	X	B/70	C	A/125	D	D	A	A
65 % Lösung (Kochen)	D	C	A	D	D	C	D	A	D	X	D	D	A	D	D	A	D
Konzentriert	D	C	A	D	D	D	D	A	D	X	D	C	A/125	D	D	A	B
Rot rauchend (RFNA)	X	D	A	D	D	D	D	B	D	X	D	C	D	D	D	A	B/70
Salpetersäure	D	X	A	X	X	X	B	A	X	X	D	X	A	D	D	B	A
Salz Soda	A	B	A	X	A	X	A	A	X	X	X	X	X	D	A	A	A
Salzsäure 20 %	D	A	A	D	D	B	A	A	A	X	A	D	A	D	D	D	A
Salzsäure 37 %	D	B	A	D	D	D	B	A	A	X	A	D	A	D	D	D	A
Salzwasser	A	A	A	X	A	D	A	A	A	A	A	A	A	D	D	C	A
Santo Safe 300	X	X	A	B	D	X	C/70	A	A	X	X	X	X	X	X	X	X
Schellack	A	A	A	D	D	D	A	A	D	X	A	A	X	A	A	A	A
Schmalzöl (heiß)	X	B	A	B	A	C	B	A	A	A	B	AA	A	A	A	A	A
Schmieröl Di-Ester	A	D	A	D	C	D	D	A	A	X	X	X	X	X	X	X	X
Petroleumbasis	B	D	A	A	B/150	B/70	D	A	B	X	C	A	A	A	A	A	A
SAE 10,20, 30, 40, 50	A	D	A	A	D	A	D	A	A	X	C	A	A	A	A	A	A
Schneidöl (Sulfur Base)	B	D	A	X	C	A	D	A	A	X	X	X	X	A	A	A	A
Schneidöl (wasserlöslich)	C	D	A	X	D	A	D	A	A	X	X	X	X	A	A	A	A
Schwarzer Punkt 77	X	X	A	X	C	C/70	A	A	X	X	X	X	X	X	X	B	X
Schwarzer Sulfat-Alkohol	X	X	A	B	B	D	B	B	A	X	X	X	A/175	C	B	A	B
Schwefel	B	A	A	X	B	B	A	A	A	X	A	A	A	A	A	A	B
Schwefelchlorid	D	D	A	C/70	A	C/70	D	A	C	X	C	D	A/70	B	D	B	A
Schwefeldioxid	D	A	A	D	A	C	A	A	A	X	A	D	A	D	D	A	B
Schwefelhexafluorid	C	B	A	B	B	B	A	C	A	X	X	D	X	D	D	X	D
Schwefelsäure - (bis 10 %)	D	A	A	A	D	D	A	A	D	X	A/120	D	A	D	D	C	A
Schwefelsäure - (bis 75 %)	D	A	A	B	D	D	C	A	D	X	A/72	D	A/150	D	D	C	B
(Rauchend) Oleum	D	A	A	B	D	D	B	A	D	X	D	D	D	C	D	B	B
konzentriert	D	B	A	C	D	D	C	A	D	X	C/72	D	A/120	D	D	B	A
Schwefelsäure - verdünnen	D	A	A	A	C	C	A	A	X	X	A	D	A	D	D	B	A
Schwefeltrioxid	D	D	A	D	A	C	C	A	X	X	D	X	C	D	D	B	B

LEITFADEN

A = Ausgezeichnet, B = Gut, C = Mittel bis Schlecht, D = Nicht empfohlen

X oder Klammern um einen Bewertungsbuchstaben bedeuten, dass keine Daten verfügbar sind.

Die Bewertungen basieren auf Belastungstests in ähnlichen chemischen Gruppen.

* Alle Angaben in Grad Celsius



MATERIAL	NITRIL	SANTOPRENE®	PTFE	HYTREL®	NEOPRENE®	URETHAN	EPR/EPDM	VITON®	UHMW-PE	LEDER	POLYPROPYLEN	ACETAL	PVDF	ALUMINIUM	GUSSEISEN	ROSTFREI	HASTELLOY®
Schwefelwasserstoff feucht	D	A	A	A	A	D	A	D	A	X	A	C	A	D	D	A	A
Schwefelwasserstoff trocken	D	A	A	A	A	A	A	D	A	A	A	A	A	B	D	B	A
Schweflige Säure	D	X	A	D	D	D	D	D	A	X	A	D	A	D	D	B	B
Schweres Wasser	A	B	X	B	X	D	A	X	X	X	X	X	X	A	C	A	A
Seifenlösungen	A	A	A	A	A	A	A	A	A	X	A	A	A	C	D	A	A
Senf	B	A	A	B	A	B	A	A	A	X	A	A	X	B	X	A	A
Sesamöl	A	B	X	X	C	X	X	A	X	X	X	X	X	X	A	A	X
Silberbromid	X	X	A/70	X	X	X	X	X	X	X	X	A	X	D	D	B	A
Silberchlorid	D	X	A/70	X	X	X	X	X	X	X	A	X	X	X	X	X	X
Silbercyanid	A	X	A	X	A	D	A	A	A	X	A	X	A	D	A	A	A
Silbernitrat	C	A	A	D	A	A	A	A	A	X	A	A	A	D	D	A	A
Siliciumtetrachlorid nass	X	X	X	X	X	X	X	X	X	X	X	X	X	X	X	X	X
Silikatester	A	B	A	C	A	B	D	A	D	X	X	X	X	X	X	X	X
Silikon-Fette	A	B	A	A	A	A	A	A	A	X	X	A	X	X	X	X	X
Silikonöle	A	C	A	B	A	A	A	A	A	X	A	A	A	B	A	A	A
Sirup	A	A	X	X	B	X	A	A	X	X	A	A	X	A	X	A	X
Skydrol 500	D	B	A	A	D	D	A	D	X	X	X	A	X	X	X	A	A
Skydrol 7000	X	B	A	D	D	D	A	B/70	X	X	X	A	X	X	X	A	A
Sojaöl	A	C	A	B	A	B/70	D	A	A	X	B	B	X	A	A	A	A
Sojasauce	A	A	X	X	A	B	X	A	X	X	X	A	X	A	D	A	X
Sole (Natriumchlorid)	A	A	A	B	B	B	A	A	A	X	A/70	A	A	C	D	A	A
Sorghum	A	A	X	X	A	X	X	A	X	X	X	A	X	X	A	A	A
Sperma Öl (Walöl)	X	B	X	X	D	X	D	A	X	X	X	X	X	X	A	A	A
Spry	X	X	X	X	B	A	B/70	A	A	X	X	X	X	X	X	X	X
SR-10 Treibstoff	X	X	X	X	D	B/70	D	A	A	X	X	X	X	X	X	X	X
SR-6 Treibstoff	X	X	X	X	D	B/70	D	A	A	X	X	X	X	X	X	X	X
Stannic Chlorid	A	A	A	B	C	B	A	A	A	X	A	B	A	D	D	D	B
Stannic Fluorborate	X	X	X	X	A	X	X	A	X	X	X	C	X	D	D	X	X
Stärke	A	A	A	B	A	A	A	A	A	A	A	B	X	A	C	A	A
Stearinsäure	B	A	A	B	B	A	B	A	A	X	B/72	A	A	B	X	A	A
Stickstoff	A	A	A	B	A	A	A	A	X	X	A	A	A	A	A	A	A
Stickstofftetroxid	D	D	A	B	D	D	D	D	A	X	D	X	C	D	D	A	A
Stoddard Lösungsmittel	B	D	A	C	D	A	D	A	X	A	A/70	A	A	A	A	A	A
Strahlung	X	X	A	X	C	B	C/70	D	X	X	X	D	X	X	X	X	X
Styrol (Vinylbenzol)	D	C	A	D	D	D	D	B	A	X	D	A	A	A	B	A	D
Sulfat Grüner Alkohol	B	A	A	B	A	A	A	A	A	X	A	D	A	B	C	A	A
Sulfit-Liquor	B	A	A	X	A	C	B/70	A	X	X	B	X	X	D	D	B	A
SunSAFE (Feuerwiderstand)																	
Hydr. Flüssigkeit	B	D	A	A	B	D	D	A	X	X	X	X	X	X	X	X	X
Talg	B	B	A	X	D	A	A	A	A	X	B/70	A	X	A	X	A	X
Tallöl	A	D	A	X	D	A	D	A	A	X	A	X	A	D	C	B	A
Teer und Teeröl	X	X	A	C	C	D	X	X	C	X	A	A	A	A	C	B	X
Terpenmonocyclisch	X	X	A	X	A	X	D	A	X	X	X	X	X	A	D	X	X
Terpentin	B	D	A	B	D	D	D	A	D	X	B/120	A	A	A	B	A	B
Terpineol	D	B	A	X	D	B/70	C/70	A	X	X	D	X	B/120	A	A	A	A
Tertiärer Butylalkohol	D	B	A	X	B	D	B/70	A	X	X	B	A	X	X	X	X	X

LEITFADEN

A = Ausgezeichnet, B = Gut, C = Mittel bis Schlecht, D = Nicht empfohlen

X oder Klammern um einen Bewertungsbuchstaben bedeuten, dass keine Daten verfügbar sind.

Die Bewertungen basieren auf Belastungstests in ähnlichen chemischen Gruppen.

* Alle Angaben in Grad Celsius



MATERIAL	NITRIL	SANTOPRENE®	PTFE	HYTREL®	NEOPRENE®	URETHAN	EPR/EPDM	VITON®	UHMW-PE	LEDER	POLYPROPYLEN	ACETAL	PVDF	ALUMINIUM	GUSSEISEN	ROSTFREI	HASTELLOY®
Tertiäres Butylmercaptan	X	B	A	X	D	D	D	A	X	X	X	B	X	X	X	X	X
Tetra Bromethan	D	D	A	X	D	X	D	A	X	X	D	X	X	D	X	X	X
Tetrabutyltitanat	X	B	A	X	B	X	A	A	X	X	X	X	X	X	X	X	X
Tetrachlordifluoethan	D	D	A	X	D	X	D	X	X	X	X	X	X	X	X	X	X
Tetrachlorethylen	D	D	A	X	D	D	D	A	B	X	D	A	A/170	D	A	A	X
Tetrachlorkohlenstoff - rein	D	D	A	D	D	A	D	A	D	X	B/70	A	A	D	C	A	A
Tetraethylblei	B	C	A	B	C	B	D	A	C	X	A	X	A	B	A	A	X
Tetraethylenglycol	X	X	A	X	X	X	X	A	X	X	X	X	X	X	X	X	X
Tetrahydrofuran	D	B	A	B	D	D	D	D	B	X	C	A	B/70	X	X	A	A
Tetralin	D	C	A	X	D	D	D	A	X	X	D	X	X	A	A	A	A
Thiokol TP-90B	X	X	X	X	B	X	A	A	X	X	X	X	X	X	X	X	X
TP-95	X	X	X	X	B	X	A	A	X	X	X	X	X	X	X	X	X
Thionylchlorid	X	X	X	X	X	X	X	X	D	X	B	B	D	C	D	D	A
Thiophen	D	D	A	X	D	X	D	C	X	X	X	X	X	X	X	X	X
Tierische Gelatine	B	B	A	X	A	A	A	A	X	X	X	X	X	X	X	A	X
Tierisches Öl (Schmalzöl)	B	B	A	B	A	C	A	A	A	X	A	A	A	A	A	A	A
Tinte (Drucker)	A	A	A	A	A	A	A	A	A	A	X	A	A	C	D	A	A
Titantetrachlorid	C	D	A	X	D	D	D	A	C	X	D	X	B	D	A	B	B
Toluidin	X	X	A	X	X	X	X	B/70	X	X	X	X	X	A	A	A	A
Toluol (Toluol)	C	D	A	C	D	D	D	B	D	X	D	A	A	A	A	A	A
Toluoldiisocyanat (Ethylen)	X	B	A	B	D	X	A	C	X	X	X	C	X	X	X	X	X
Tomatenmark & Saft	A	A	A	X	A	A	A	A	A	X	A	A	A	B	X	A	A
Transformatorenöle	B	D	A	X	B	A	D	A	A	X	B/70	A	A	A	A	A	A
Traubensaft	A	A	X	X	A	D	A	A	A	X	A	B	A	B	D	A	X
Traubenzucker	A	A	A	B/140	B	A	A	A	A	X	A	X	A	A	D	A	A
Triacetin	X	A	A	X	B	D	A	D	X	X	X	X	X	B	X	X	X
Triarylphosphat	D	X	A	X	D	D	A	A	A	X	B	X	A	X	X	X	X
Tributoxyethylphosphat	X	B	A	X	D	D	A	A	A	X	X	X	X	X	X	X	X
Tributyl Mercaptan	X	B	A	X	D	X	D	A	A	X	X	X	X	X	X	X	X
Tributylphosphat	D	B	A	C	D	D	B	D	X	X	B	X	A	A	A	A	X
Trichlorbenzole	X	X	A	X	D	D	X	A	X	X	X	X	X	D	A	A	B
Trichloressigsäure	D	B	A	D	D	D	B/70	D	C	X	B/140	D	A70	D	D	D	B
Trichlorethan	D	D	A	D	D	D	D	A	D	X	D	A	B/150	D	A	A	A
Trichlorethylen (Triade)	D	D	A	D	D	D	D	C	X	X	C/70	B	A	B	B	B	B
Trichlormonofluoethan (Freon 17)	D	X	X	X	D	X	X	X	X	X	X	X	X	A	X	A	A
Trichlorpropan	D	D	A	X	A	A	X	A	X	X	D	A	X	D	A	A	A
Trichlortrifluoethan (Freon 113)	A	D	A	A	A	B	D	A	X	X	A	X	A	A	A	A	A
Tricresylphosphat	D	B	A	C	C	D	A	A	A	X	B	C	D	D	A	A	A
Tridecylalkohol (Tridecanol)	X	X	A/170	X	X	B	X	B/70	X	X	X	X	X	X	X	X	X
Triethanolamin	D	A	A	C	A	D	A	D	A	X	A/70	A	A	B	A	A	A
Triethylaluminium	X	B	A	D	D	X	X	B/70	X	XX	X	X	X	X	X	X	X
Triethylamin	D	D	A	X	B	D	A	A	X	XX	C	A	A/120	X	A	A	A
Triethylboran	X	B	A	X	D	X	X	A	X	X	X	X	X	X	X	X	X
Triethylenglycol (TEG)	A	X	A	X	X	X	X	A	A	X	A	X	X	X	X	X	X
Trifluoethan	X	X	A	X	D	D	D	A	X	X	X	X	X	X	X	X	X

LEITFADEN

A = Ausgezeichnet, B = Gut, C = Mittel bis Schlecht, D = Nicht empfohlen

X oder Klammern um einen Bewertungsbuchstaben bedeuten, dass keine Daten verfügbar sind.

Die Bewertungen basieren auf Belastungstests in ähnlichen chemischen Gruppen.

* Alle Angaben in Grad Celsius



MATERIAL	NITRIL	SANTOPRENE®	PTFE	HYTREL®	NEOPRENE®	URETHAN	EPR/EPDM	VITON®	UHMW-PE	LEDER	POLYPROPYLEN	ACETAL	PVDF	ALUMINIUM	GUSSEISEN	ROSTFREI	HASTELLOY®
Trimethylenglykol	X	X	A	X	X	X	A	A	X	X	X	X	X	X	X	X	X
Trinatriumphosphat	A	A	A	A	A	B	A	A	X	X	A	D	A	D	A	B	A
Trinitrotoluol (TNT)	X	A	A	X	B	X	D	B/70	X	X	X	X	X	X	X	X	X
Trioctylphosphat	X	B	A	X	D	D	A	B	X	X	X	X	X	X	X	X	X
Triphenylphosphit	D	X	A	X	X	X	X	C/70	X	X	X	X	X	X	X	X	X
Trockene Reinigungsflüssigkeit	D	D	A	X	D	D	D	A	D	X	D	X	A	A	A	A	X
Tungöl	D	B	A	(B)	A	B	D	A	A	X	A	X	A	A	B	A	A
Turbinenöl #15 (Mil -L-7808A)	X	X	A	X	D	D	D	A	X	X	X	X	X	X	X	X	X
Turbinenöl	X	X	A	X	B	A	D	A	X	X	X	X	X	X	X	X	X
Turbo Öl #35	X	X	X	X	B	A	D	A	X	X	X	X	X	X	X	X	X
Typ 1 Treibstoff (Mil-S-3136)	X	D	A	A	A	B	D	A	X	X	X	X	X	X	X	X	X
Typ 11 Treibstoff (Mil-S-3136)	X	D	A	X	D	B/70	D	A	X	X	X	X	X	X	X	X	X
Typ 111 Treibstoff (Mil-S-3136)	X	D	A	A	D	B/70	D	A	X	X	X	X	X	X	X	X	X
Univis 40 (Hydr. Flüssigkeit)	X	D	A	X	B	A	D	A	X	X	X	X	X	X	X	X	X
Univolt #35 (Mineralöl)	X	C	A	X	B	A	D	A	X	X	X	X	X	X	X	X	X
Unsymmetrisches Dimethylhydrazin	X	B	A	X	B	D	A	D	X	X	X	X	A/70	B	A	A	X
Urin	A	A	A	X	D	X	A	A	A	X	A	C	A	B	B	A	A
Valeriansäure	X	X	A	X	D	X	A	X	X	X	X	X	X	A	X	X	X
Vanilleextrakt	X	A	A	X	A	X	X	X	A	X	X	X	X	X	X	A	X
Versilube F-50	X	X	A	X	A	A	A	A	A	X	X	X	X	X	X	X	X
Versilube	X	X	A	X	A	A	A	A	A	X	X	X	X	X	X	X	X
Vinylacetat	D	B	A	X	D	D	B	A	D	X	B/80	X	A	B	A	A	A
Vinylchlorid (Chlorethylen)	X	X	A	X	D	X	C	A	X	X	D	X	A	D	B	A	A
Wachse	D	X	A	X	A	A	B	A	A	X	D	A	D	D	D	D	A
Walnussöl	X	X	A	X	B	X	X	A	X	X	X	X	X	X	X	X	X
Wasserfreies Ammoniak	B	A	A	D	D	D	A	D	X	X	A/70	D	D	B	D	A	A
Wasserfreies Fluorwasserstoff	D	C	A	X	X	D	A	D	X	X	X	X	X	X	X	X	X
Wasserfreies Hydrazin	D	X	A	X	B	D	B	D	X	X	X	X	X	X	X	X	X
Wasserstoff	A	A	A	A	A	A	B	A	A	X	X	X	X	X	X	X	X
Wasserstoffperoxid	C	A	A	D	D	C	C	A	A	X	A/70	D	A/70	A	D	A	A
Weinsäure	B	A	A	(B)	A	A	C	A	A	X	A	D	A	A	D	A	A
Weißer Schnaps (Zellstoffmühle)	A	A	A	X	A	D	A	A	X	X	X	X	X	X	X	X	X
Weißes Öl	X	C	A	X	B	A	D	A	X	X	X	A	X	X	X	A	A
Weißkieseröl	X	A	A	D	D	X	D	A	A	X	X	A	X	X	X	X	X
Wemco C	X	X	A	X	B	A	D	A	X	X	X	A	X	X	X	A	X
Whisky und Weine	A	A	A	B	A	D	A	A	A	X	A	A	A	D	D	A	A
Wolmar Salz	X	X	A	X	B	A	A	A	X	X	X	X	X	X	X	X	X
Xylol (Xylol)	C	D	A	B	D	D	D	A	D	X	B	A	A	A	A	A	A
Zellultherm 2505A	C	D	A	D	D	D	D	A	X	X	X	X	X	X	X	X	X
Zeolithe	X	A	A	X	C	X	A	A	X	X	X	X	X	X	X	A	A
Zerstreuendes Öl #10	D	X	A	X	D	X	D	C	X	X	X	X	X	A	A	A	A
Zimt Öl	X	C	A	X	C	X	X	X	X	X	X	X	X	X	D	A	X
Zink Hydrosulfit	A	A	(A)	X	A	X	A	X	X	X	X	C	A	D	X	A	X
Zinkacetat	B	A	A	X	B	D	A	B	A	X	A	X	A	C	X	A	X
Zinkcarbonat	A	A	A	X	A	A	A	A	A	X	X	X	X	B	B	B	B

LEITFADEN

A = Ausgezeichnet, B = Gut, C = Mittel bis Schlecht, D = Nicht empfohlen

X oder Klammern um einen Bewertungsbuchstaben bedeuten, dass keine Daten verfügbar sind.

Die Bewertungen basieren auf Belastungstests in ähnlichen chemischen Gruppen.

* Alle Angaben in Grad Celsius



MATERIAL	NITRIL	SANTOPRENE®	PTFE	HYTREL®	NEOPRENE®	URETHAN	EPR/EPDM	VITON®	UHMW-PE	LEDER	POLYPROPYLEN	ACETAL	PVDF	ALUMINIUM	GUSSEISEN	ROSTFREI	HASTELLOY®
Zinkchlorid	A	A	A	A	A	A	A	A	A	X	A	D	A	D	D	C	A
Zinksalze	A	A	A	X	A	A	A	A	X	X	A	X	A	X	X	X	X
Zinksulfat	A	A	A	C	A	A	A	A	A	X	A	C	A	D	D	A	A
Zinnchlorid	A	B	A	B	A	C	B	A	X	X	A	X	A	D	B	A	A
Zinntetrachlorid	A	X	A	X	D	B/70	X	X	X	X	A	X	A	D	D	D	A
Zitronenöl	X	C	A	X	C	X	C	A	X	X	X	X	X	A	X	A	X
Zitronenöle	B	C	A	X	D	X	B	A	A	X	A	B	X	C	D	A	X
Zitronensäure - 5 % Lösung	A	A/70	A	B/70	A	A/70	A	A	A	X	A	C	A	C	D	A	A
Zuckerflüssigkeiten	A	A	A	B	A	D	A	A	A	A	A	A	A	A	A	A	A
Zuckerflüssigkeiten	B	A	A	B	A	A	A	A	A	X	A	D	A	B	C	A	A
Zuckerrohr-Liköre	A	A	A	B	A	D	A	A	X	X	A	X	A	A	B	A	X

Santoprene® ist eine eingetragene Marke der Advanced Elastomer Systems, L.P.

Hytrel® ist eine eingetragene Marke der E.I. du Pont de Nemours and Company.

Neoprene® ist eine eingetragene Marke der DuPont Corporation.

Viton® ist eine eingetragene Marke der DuPont Dow Elastomers.

Hastelloy® ist eine eingetragene Marke der Haynes International, Inc.

- Während der letzten acht Jahrzehnten haben die Produkte zum Flüssigkeitsmanagement von ARO Unternehmen wettbewerbsfähiger, kosteneffizienter und leistungsfähiger gemacht.

Kontaktieren Sie uns noch heute bezüglich Ihren Anforderungen.



www.AROzone.com



fluid_management_emea@irco.com



Vertrieb durch:

ARO Pumpen - NDI tec GmbH

Scherpheisterweg 3 46509 Xanten

Tel.: 02801 9879-370 Fax: 02801 9879-379

Mail: vertrieb@aro-pumpen.de

www.aro-pumpen.de www.aro24.de

www.AROzone.com

fluid_management_emea@irco.com

youtube.com/aropumps

ARO®

ARO® ist eine Marke von Ingersoll Rand. Ingersoll Rand (NYSE:IR) fördert die Lebensqualität durch Schaffung von komfortablen, nachhaltigen und effizienten Umgebungen. Unsere Mitarbeiter und unser Markenportfolio – darunter Club Car®, Ingersoll Rand®, Thermo King® und Trane® – tragen gemeinsam dazu bei, die Qualität und Behaglichkeit der Luft in Häusern und Gebäuden, den Transport und Schutz von Nahrungsmitteln sowie verderblichen Waren, sowie die industrielle Produktivität und Effizienz zu steigern. Wir sind ein globales Wirtschaftsunternehmen mit einem Wert von 12 Mrd. USD und konzentrieren uns auf nachhaltigen Fortschritt und beständige Ergebnisse.